

Flood Early Warning in Rivers Based on ESP8266 Microcontroller and Arduino Nano

Dwi Mulyani*

Information System, STMIK Banjarbaru, Banjarbaru, Indonesia

Email: dwinaubel@gmail.com

ORCID iD: <https://orcid.org/0000-0003-1541-4305>

*Corresponding Author

Siti Abidah

Information System, STMIK Banjarbaru, Banjarbaru, Indonesia

Email: abi.bjb@gmail.com

ORCID iD: <https://orcid.org/0009-0002-7628-0486>

Masniah

Information Technology, STMIK Banjarbaru, Banjarbaru, Indonesia

Email: niazetta1@gmail.com

ORCID iD: <https://orcid.org/0000-0003-2994-3742>

Heru Kartika Candra

Accounting Computer, Politeknik Negeri Banjarmasin, Banjarmasin, Indonesia

Email: herukcandra@poliban.ac.id

ORCID iD: <https://orcid.org/0009-0003-1728-9234>

Received: 07 October, 2024; Revised: 03 January, 2025; Accepted: 12 March, 2025; Published: 08 October, 2025

Abstract: Information about the arrival of floods in rivers must be informed as soon as possible to the community so that it can save people along the river and its surroundings from the dangers of flooding which are very detrimental. Arduino Nano and Microcontroller ESP8266 provide good performance in providing information about the arrival of floods quickly. The working system of the tool is based on a water level sensor installed in the upstream area of the river which will be received and processed by Arduino nano, then the sensor data is communicated to the ESP8266 device (as a wifi node). Furthermore, ESP8266 will send information to the Android application. This system is very cost-effective and has low power consumption. Flood information will be sent to people along the river that flows through the city and residential areas. The test results show that the current system is functioning well, and is useful for flood monitoring systems in rivers.

Index Terms: Arduino Nano, ESP8266, Flood Early Warning

1. Introduction

Floods are one of the disasters that often occur in several countries. Disasters caused by hydrometeorological factors always increase every year. Although sometimes it does not cause many casualties, this disaster still damages infrastructure and significantly disrupts the stability of the community's economy. Floods can affect the entire country especially urban areas and cause significant economic and human losses. The problem currently being faced is flooding caused by river overflows onto land around the river. This is because the rain in the upper reaches of the river is very heavy, causing the river water to exceed its capacity and overflow, causing flooding along the river basin. This flood is not realized by the community because it comes from the upper reaches of the river and occurs very quickly, so that residents only have time to save themselves and do not have time to save valuables and electronics in their homes. Floods have an impact on the social, economic and health lives of the community. Damage and loss of important personal belongings can have a negative psychological impact on flood victims [1]. In addition to the economic impact, floods also have an impact on public health. Many diseases are caused by floods [2]. This results in many losses borne by the community. The purpose of this study is to design a tool that can provide information on flooding in rivers

quickly to the community, especially those living along the river. Because they are the ones most quickly affected by flooding and its consequences. The tool developed is a tool that can detect water levels based on Arduino Nano and ESP6288 Microcontroller. ESP8266 provides an HTML-based user interface to computers and mobile devices connected to the CIoT network via the TCP/IP protocol. It has used a WiFi connection as an access point [3]. The ESP8266 microcontroller has a good CPU frequency, with larger flash memory and RAM (random access memory). The sketch is stored in flash memory, while the sketch variables are stored in RAM [4]. The working process of the tool is that the tool is placed in the river flow upstream. The sensor installed on the tool will detect the water level of the river. Then the sensor will be received by the Arduino Nano device. The data received will be processed and forwarded by the ESP6288. ESP 6288 acts as a wifi node that is tasked with sending information to the android application and received by the community. The community will receive messages about the condition of the river upstream. So when they get an emergency message, they can prepare to save themselves and their belongings. The use of this tool is considered very profitable because the installation costs are cheap and energy efficient[5].

1.1. Arduino Nano

Arduino is a prototype and platform that is a combination of hardware and software. Arduino uses open source libraries available on the internet[7]. Arduino Nano was created based on the ATmega328 microcontroller (for Arduino Nano version 3.x) or ATmega 168 (for Arduino version 2.x). Arduino Nano has more or less the same function as Arduino Duemilanove, but in a different package. Arduino Nano does not include a Barrel Jack DC plug, and is connected to a computer using a USB Mini-B port. Arduino Nano is designed and manufactured by the Gravitech company[8]. Here is a view of Arduino Nano.

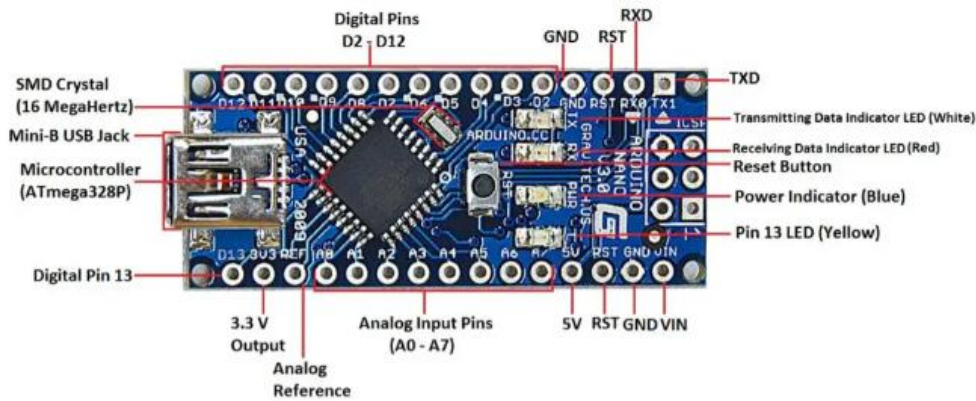

Fig. 1. Arduino Nano V3

Fig 1 Arduino Nano V3 which is a compact, complete, and breadboard-friendly microcontroller board. The Nano board weighs about 7 grams with dimensions of 4.5 cm to 1.8 cm (from left to right). Arduino Nano with ATmega328P microcontroller is available in TQFP (plastic quad flat pack) form with 32 pins. 2 additional pins Arduino Nano for ADC function. Nano board has a mini-USB port used for programming and serial monitoring. An interesting feature of Nano is that it will select the strongest power source with its potential difference and the power source selection jumper is invalid. Operating Voltage of 5 Volts with 16MHz Speed, Input voltage (7-12) Volts

1.2. Node MCU ESP8266

Microcontrollers have been used as digital systems that have been widely applied in household and industrial electronics. Microcontrollers are chosen because of their affordable prices. Microcontrollers are usually used as control systems, signal processing, instrumentation, and others [6]. The specifications owned by NodeMCU are as follows:

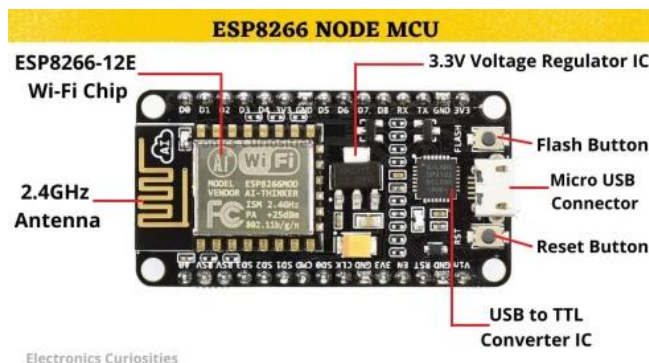

Fig. 2. NodeMCU ESP8266

Fig 2. NodeMCU ESP8266. IoT module based on ESP8266 wifi chip which has USB to TTL Converter IC CH340g inside which is fully integrated and contains Wi-Fi network. ESP8266 WiFi module with ESP-12 SMD footprint. WiFi upgrade has installed all ESP8266 code (ESP-12E). Equipped with 2 buttons, namely reset button and flash button. The package size is QFN 32pin with a size of 5mm x 5mm. Energy requirements Operating voltage: 2.5 to 3.3 v. Built-in power control 3.3v 600mA Operating current 800mA

1.3. Ultrasonic Sensor Hc-Sr04

Ultrasonic sensors are essentially sound sensors, but they operate at frequencies above human hearing. The sensor sends out sound waves at a specific frequency. The sensor then listens for those specific sound waves to bounce off an object and return[9]. These sensors offer excellent non-contact distance detection with high accuracy and stable readings in an easy-to-use package from 2 cm to 400 cm or 1" to 13 feet. Their operation is not affected by sunlight or dark materials, although acoustically, soft materials such as cloth are difficult to detect. These sensors are equipped with ultrasonic transmitter and receiver modules[10].

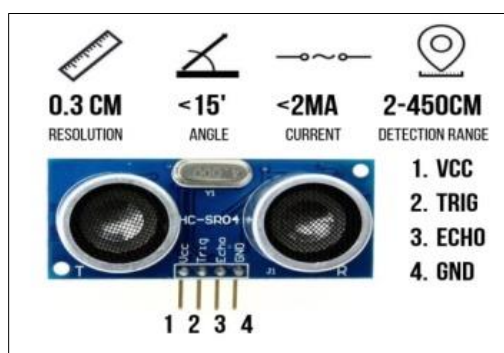

Fig. 3. Ultrasonic Sensor HCSR04

Fig 3. Ultrasonic sensor HC SR04. A sensor that converts sound into electrical quantities and vice versa. The specifications of the Ultrasonic sensor HC SR04 used are Working Voltage 5 V DC, Working Current 15mA, Working Frequency 40Hz, Max Range 4 m, Minimum Range 2 cm, Measuring Angle 15 degrees, Trigger Input Signal 10uS, TTL pulse Echo Output Signal, Input TTL lever signal and the range in proportion.

1.4. Telegram

Telegram was launched in 2013 by Nikolai and Pavel Durov, They also founded the largest social network in Russia, VK Russia. Telegram Messenger LLP is registered as an independent non-profit company in Berlin, Germany. The founders claim that Telegram is faster and safer than other applications and more importantly messages sent via Telegram cannot be intercepted by third parties[12]. Telegram is indeed an encrypted social media application that is very difficult to penetrate or intercept by law enforcement. [13]

Telegram has a large storage capacity so that it can upload files simultaneously. Telegram is widely used as a social media and communication in several countries.



Fig. 4. Telegram Logo

Fig 4. Telegram Application. Telegram application is a media used to convey information sent from the device because it is widely used by the community and has a wide reach. Telegram application is easy to install on mobile devices and easy to operate

2. Literature Review

Yoice R.Putung and friends created a room temperature and humidity control system using Arduino Nano based on the Web using temperature and humidity sensors (DHT11 sensors). The system is equipped with a Buzzer that will work when the temperature is above 30 degrees. In addition, it is also equipped with an LED used to indicate conditions, a green LED for temperatures below 30 degrees and a red LED for temperatures above 30 degrees. The fan is installed indoors and will work (turn on) if the temperature is above 30 degrees. To display web-based data, NodeMCU ESP8266 v.3 is used which can send sensor data to the web. From the test results, the temperature and humidity monitoring system designed using the DHT11 sensor, Arduino Nano, and NodeMCU can display monitoring data with web output in real time. If the temperature is ≥ 30 , the red light will turn on, the green light will turn off, the buzzer will be active. If the temperature is not ≥ 30 , the red light will turn off, the green light will turn on. [18]

Adi Winarno and friends created a smart home system to control electronic equipment that can be operated via an internet connection (WiFi). According to Rahayu and Nurdin, Automation of electronic devices as a solution makes it easier for humans to carry out routine activities in daily activities.[19]. The system is designed using the ESP8266 microcontroller and the blynk application as a controller. The system consists of a light controller, humidity and room temperature sensors, detecting human movement in abandoned houses, early detection of fire sources to prevent house fires, and LPG gas leak detectors for home security. The design of this system uses a relay which is used as a connection between the lights and the system. From the test results, it can be concluded that the ESP8266 functions properly. This test was carried out starting from the tool to connecting to IoT. In the test, all tools worked well according to the design, from the tool that must be supplied with electricity, then the tool must be connected to registered internet access.[20].

Adril Arnas et al designed a prototype parking device to make it easier for drivers to find empty parking slots. The device to be built will turn on when the car enters the parking area and is detected by the TCRT-5000 sensor, then the servo opens the gate on command from Arduino and the driver looks for an empty parking space. The driver can see the empty parking slot through the parking application connected to the database via NodeMcu ESP8266. The LCD will output letters and numbers. From the test results, it can be concluded that the Smart Parking Prototype Design with the Nodemcu Esp 8266 microcontroller will be connected to firebase and android. This design uses hardware in the form of Esp 8266, Arduino nano TCRT-5000, Servo motor, LCD, Wire jumper. This design uses software in the form of Arduino IDE and App Inventor. With this smart parking design, finding a parking slot becomes easier and neater. [21]

Nadiyah Nordin et al designed a remote electrical equipment control device to reduce electricity bills. This project system works by using Arduino Nano with ESP8266 Wi-Fi module connection. Users can control the switching of electrical loads online by using a phone while interacting with the Blynk platform. In addition, this system also includes an online power monitoring system using the ACS712 current sensor to monitor the amount of current and power consumption for home electrical loads that will be displayed in the Blynk application.[22]. This system potentializes the efficient use of electrical energy, leading to significant environmental, political and economic benefits[23].

AS Dige et al created a device to monitor air quality using Arduino and ESP8266. The sensors will detect pollutants in the air. The sensors provide sentiments of various types of harmful gases and Arduino is the center that controls the entire method. The WiFi module connects the entire system to the web. For additional enhancements, more sensors can be added to take more boundaries to be free from air contamination and protect against its harmful effects.[24]

Tsyrlunyk S at al. proposed a remote control system for monitoring temperature and humidity of educational institutions using the weighted moving average method. This technique uses a wireless control module with an ESP8266 microcontroller using a Wi-Fi channel, which is integrated into the Internet of Things system. The microcontroller measures temperature and humidity and then the measurement results via a Wi-Fi network to the IoT cloud, and remotely controls the load, which is connected to the 220 V electrical network through a relay module. The proposed system can be improved and integrated into a centralized climate control system in educational institutions, which in turn will allow efficient use of financial resources.[25]

3. Methodology

In this study, the components used are Arduino Nano, HC-SR04 Ultrasonic Sensor, NodeMCU Esp 8266, Wireless used is IEEE 802.11b/g/n, and power supply. The entire system on this device is powered by a power supply. The HC-SR04 Ultrasonic Sensor functions as a water level measuring sensor. The Arduino Nano microcontroller functions as a controller, receiver, and data processor from the HC-SR04 Ultrasonic Sensor, the measurement results of the HC-SR04 Ultrasonic Sensor will be displayed in the form of a light that will light up according to the water level sensor. In addition, the results of the HC-SR04 Ultrasonic Sensor that have been processed by the Arduino nano will also be forwarded by the ESP8266 which acts as a wifi node to the Android device via the Telegram application. The following is a Block Diagram of the flood early warning circuit in rivers with Arduino Nano and ESP6288. The following is a block diagram of the flood early warning system circuit in rivers with Arduino Nano and ESP6288.

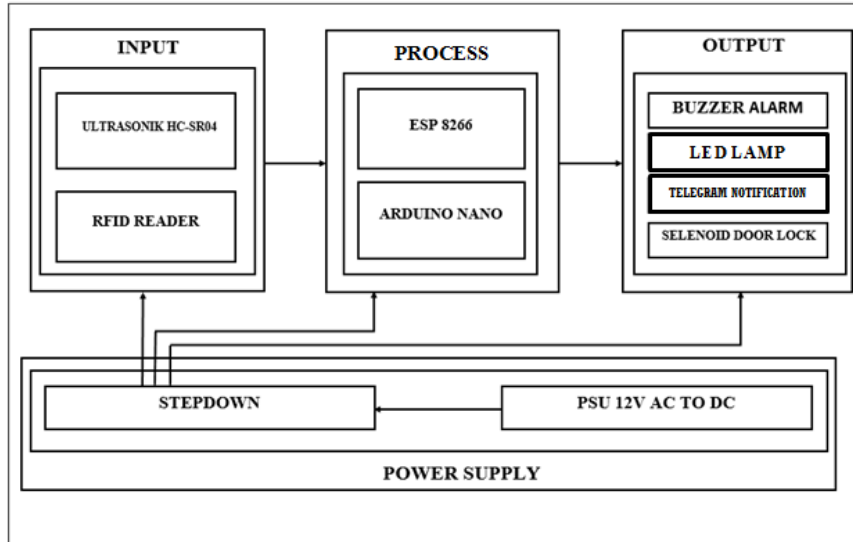

Fig. 5. Block Diagram

Fig 5. Block diagram. Describes the relationship between components and device circuits. The blocks consist of

1. Power Supply Block

The power supply block is a block that contains components, namely PSU 12v AC to DC, Stepdown 1m 2596 which functions as the main voltage source as input to the Input Block, Process Block, and Output Block.

2. Input Block

The input block consists of an HC-SR04 Ultrasonic Sensor to monitor water levels, and an RFID Reader to open the circuit box door.

3. Process Block

The process block is the part where the microcontroller controls all commands, there are esp8266 and arduino nano.

4. Output Block

The Output Block is the result of the entire circuit, which in this circuit has an alarm buzzer, LED lights and door lock solenoid

3.1. Tools Design

The following is a component configuration plan for the Flood Early Warning Prototype Based on the ESP8266 Microcontroller and Arduino Nano.

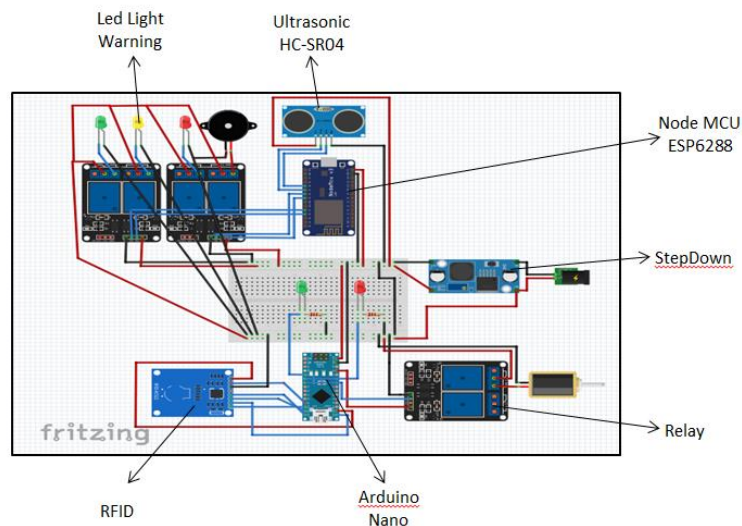

Fig. 6. Component Configuration

Fig 6 Component Configuration. The image is a component configuration plan of the Early Flood Warning Prototype Based on the ESP8266 Microcontroller and Arduino Nano. Consisting of a series of components including Arduino Nano, HC-SR04 ultrasonic sensor, NodeMCU ESP266, Stepdown, Led Light Warning, several relays, cables and others.

3.2. Ultrasonic Sensor Reading Design And Prototype Size

Fig. 7 Ultrasonic Sensor Reading Design. In the image above, the overall prototype design length is 100cm with a height of 150cm. The pipe length is 70cm and the height is 65cm. The ultrasonic sensor reading is seen in the image based on the color of the light output. Blue is SAFE WATER status, green is ALERT 3 status, yellow is ALERT 2 status, red is ALERT 1 status.

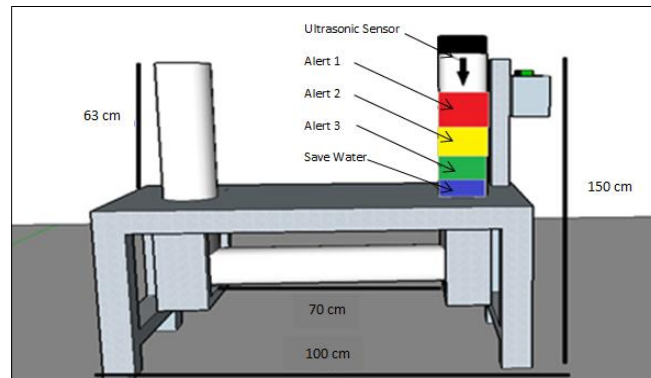

Fig. 7. Ultrasonic Sensor Reading Design

3.3. Water Level Monitoring Notification Via Telegram

Fig 8. Water level monitoring notification via telegram. The image above is a design of the automatic notification receipt flow for telegrams using the bot available on telegrams where the Telegram bot Http Api Token has been inputted as the identity or notification destination from the prototype to the Telegram application. The following Telegram bot can be seen in the image below:

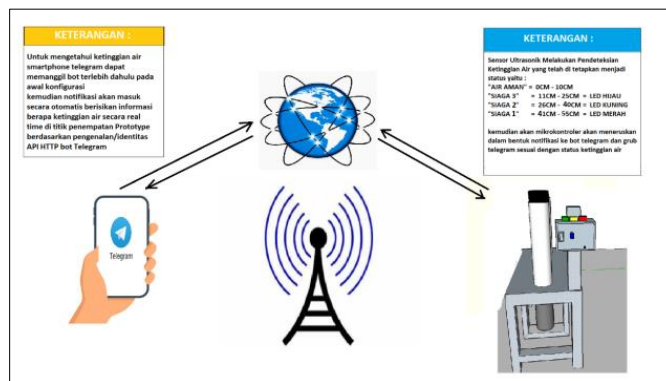

Fig. 8. Water Level Monitoring Notification Via Telegram

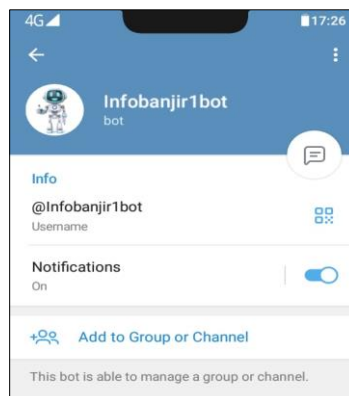

Fig. 9. Bot Telegram Design

Fig 9. Bot Telegram. It is a design of a telegram bot that will be used to receive information sent by a flood detection device. In the telegram bot, a group will be created containing groups of people who live around the river.

4. Results and Discussion

4.1. Tools Design Result

After going through the design and testing process, several tool design results were obtained as follows.



Fig. 10. Prototype of Water Level Monitoring Component

Fig 10. Prototype of Water Level Monitoring Component. It is a prototype of a water level monitoring component which can be explained as follows:

1. Placement of the HC-SR04 Ultrasonic Sensor which functions to detect and measure water levels
2. Connected vessel pipe to detect water levels
3. Connected vessel pipe where water enters
4. Out pipe to reduce water levels

The following is a picture of the Prototype Water Level Monitoring Pipe



Fig. 11. Prototype Water Level Monitoring Pipe

Fig 11. Prototype Water Level Monitoring Pipe. On the pipe above there are three levels of water height and there is a water level sensor. The pipe is colored according to the water level. Blue for safe water conditions, green for "Alert 3" conditions if the water level reaches 25cm, yellow for "Alert 2" conditions if the water level reaches 40cm, red for "Alert 1" conditions if the water level reaches 55cm.



Fig. 12. Placement of Warning Lights on the Prototype

Fig 12. The image above shows the placement of warning lights on the prototype which can be explained as follows:

1. Green light that will light up when the water level reaches alert 3
2. Yellow light that will light up when the water level reaches alert 2
3. Red light that will light up when the water level reaches alert 1

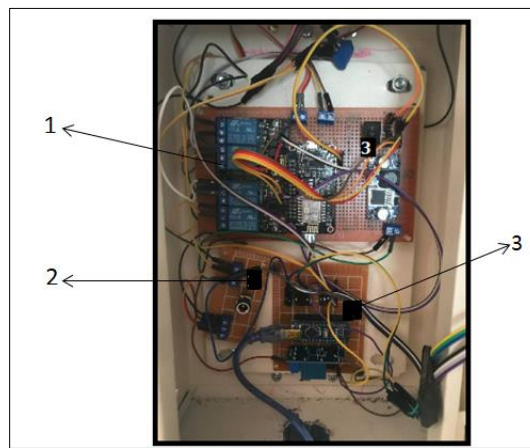

Fig. 13. Component Placement in Panel Box

Fig 13. Component Placement. The image above is the result of a prototype of a microcontroller circuit placed in a panel box which can be explained as follows:

1. Main circuit
2. Power supply PCB
3. Arduino Nano PCB connected to RFID Reader, 2 5mm LED lights, and a relay connected to the door lock solenoid

NodeMcu PCB connected to wifi and telegram, HC-SR04 ultrasonic sensor, Green LED light, Yellow LED light, Red LED light

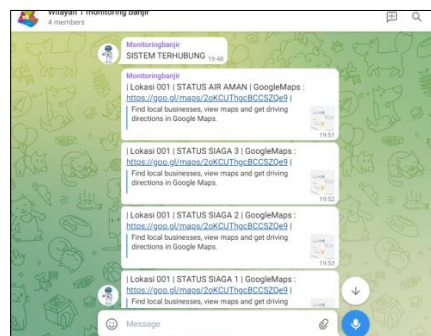

Fig. 14. Telegram Notification

Fif 14. Telegram Notification. The image above is a Telegram notification received when the water level reaches alert status which can be explained:

1. Connected System = Telegram notification received when the Microcontroller is connected to the telegram
2. SAFE WATER STATUS = Telegram notification received when the water level reaches 10 cm above the ground
3. ALERT STATUS 3 = Telegram notification received when the water level reaches 25 cm above the ground
4. ALERT STATUS 2 = Telegram notification received when the water level reaches 40 cm above the ground
5. ALERT STATUS 1 = Telegram notification received when the water level reaches 55 cm above the ground

4.2. Prototype Testing Result

To provide an assessment of the quality of the usability of the Flood Early Warning Tool Prototype Based on the ESP 8266 Microcontroller and Arduino Nano. Instrument testing is carried out to determine the extent to which the The prototype created can solve the problem. In testing this instrument is done in the form of observation of the results of the experiment. Testing is done at several water height conditions

1. Water status at a safe height between 0 to 10 cm,
2. Water status at Alert 3, namely when the water height reaches 25 cm,
3. Water status at Alert 2, namely when the water height reaches 40 cm,
4. Water status at Alert 1, namely when the water height reaches 55 cm.

Table 1. Prototype Testing Results

Input Parameter	Success	No	Output Parameter
Conditioning the ultrasonic sensor at the water level 1. "SAFE WATER STATUS" 2. "ALERT STATUS 3" 3. "ALERT STATUS 2" 4. "ALERT STATUS 1"	✓		1. Telegram notification "SAFE WATER STATUS" 2. Telegram notification "ALERT STATUS 3", green light on 3. Telegram notification "ALERT STATUS 2", yellow light on 4. Telegram notification "ALERT STATUS 1", red light on

Table 1. Prototype Testing Results. From the table, it can be seen that the prototype test results successfully passed several parameters where the prototype has run well according to each predetermined function.

4.3. Water Level Status Testing Result

Water level status testing was carried out 10 times on the HC-SR04 ultrasonic sensor. Each test was carried out on the water level status, namely the "safe water" status at a height of 0-10 cm, the "Alert 3" status at a height of 25 cm, the "Alert 2" status at a height of 40 cm, the "Alert 1" status at a height of 55 cm, if the test is successful, it will produce a notification on Telegram that conveys information about the water level status. If it fails, it will produce an output that does not match the success point. The following is a table of water level status test results.

Table 2. Water Level Status Test Results

No.	Testing	Water Level Status			
		Water Save	Alert 3	Alert 2	Alert 1
1.	Testing 1	Success	Success	Success	Success
2.	Testing 2	Success	Success	Success	Success
3.	Testing 3	Success	Success	Success	Success
4.	Testing 4	Success	Success	Success	Success
5.	Testing 5	Success	Success	Success	Success
6.	Testing 6	Success	Success	Success	Success
7.	Testing 7	Success	Success	Success	Success
8.	Testing 8	Success	Success	Success	Success
9.	Testing 9	Success	Success	Success	Success
10.	Testing 10	Success	Success	Success	Success
Success Per MH Water Level Sensor		100%	100%	100%	100%
Total Success Overall		100%			

Table 2. Water Level Status Test Results. In the water level status test table with 10 tests, the results showed that in the "Safe Water" status, all tests were 100% successful, in the "Alert 3" status test, all tests were 100% successful, in the "Alert 2" status test, all tests were 100% successful, and in the "Alert 1" status test, all tests were 100% successful. So it can be concluded that the HC-SR04 ultrasonic sensor can work well.

4.4. Led Light Warning Testing Result

LED lights are used to indicate that the device is working properly. The LED warning light test was carried out 10 times. Each test will be carried out at a different water level. The LED lights tested consist of 3 lights with green, yellow, and red colors. Each color indicates the water level. Green indicates the water level at "Alert 3", Yellow indicates the water level at "Alert 2" and red indicates the water level at "Alert 1". If the test process is successful, the light will turn on and if it fails, the light will remain off. The following table shows the results of the LED warning light test.

Table 3. Led Light Warning Test Results

No	Testing	Led Lamp		
		Green	Yellow	Red
1.	Testing 1	Success	Success	Success
2.	Testing 2	Success	Success	Success
3.	Testing 3	Success	Success	Success
4.	Testing 4	Success	Success	Success
5.	Testing 5	Success	Success	Success
6.	Testing 6	Success	Success	Success
7.	Testing 7	Success	Success	Success
8.	Testing 8	Success	Success	Success
9.	Testing 9	Success	Success	Success
10	Testing 10	Success	Success	Success
Buzzer Alarm Warning Test Results Success Per Led Light Color		100%	100%	100%
Total Overall Success		100%		

Table 3. Led Light Warning Test Results. In the LED lamp testing table, there are 10 tests, the green LED lamp test is 100% successful, the yellow LED lamp test is 100% successful, and the red LED lamp test is 100%. So it can be concluded that the total of 10 tests is 100% successful so that it can be stated that the tool can work well.

4.5. Telegram Notification Warning Testing Result

Testing was carried out 10 times based on water level status warnings, namely "Water is safe" status at a height of 0-10 cm, "Alert 3" status at a height of 25 cm, "Alert 2" status at a height of 40 cm, "Alert 1" status at a height of 55 cm, the indicator of success is that the telegram application receives a water level warning message according to the tested water level status, and if it fails, the telegram application does not receive a warning message or receives a warning message that does not match the tested water level status. The following is a table of Telegram notification warning test results.

Table 4. Telegram Notification Testing Result

No	Testing	Telegram Notification			
		Water Save	Alert 3	Alert 2	Alert 1
1.	Testing 1	Success	Success	Success	Success
2.	Testing 2	Success	Success	Success	Success
3.	Testing 3	Success	Success	Success	Success
4.	Testing 4	Success	Success	Success	Success
5.	Testing 5	Success	Success	Success	Success
6.	Testing 6	Success	Success	Success	Success
7.	Testing 7	Success	Success	Success	Success
8.	Testing 8	Success	Success	Success	Success
9.	Testing 9	Success	Success	Success	Success
10	Testing 10	Success	Success	Success	Success
Success Based on Water Level		100%	100%	100%	100%
Total Overall Success		100%			

Table 4. Telegram Notification Testing Results. From the table of 10 telegram notification alert tests, the notification test on the "Safe water" status was 100% successful, the notification test on the "Alert 3" status was 100% successful, the notification test on the "Alert 2" status was 100% successful, and the notification test on the "Alert 1" status was 100%. So it can be concluded from a total of 10 tests, it was 100% successful so that it can be stated that the tool can work well and can convey information as expected.

The design above is a means of testing equipment to show that the components can function properly. In order to be applied in a real environment properly, the government should develop better equipment, with better quality components and better designs that support its application in the existing environment. Overall, after the equipment is applied in the river area, to ensure that the equipment can work properly, periodic checks are needed. Checks can be done once a week. Make sure each component is still functioning properly. Make sure the electricity network and telecommunications network remain on. Each is the responsibility of the Electricity and Telecommunications Network Provider. In this case, the government handles it.

5. Conclusion

After going through the testing process, the early detection tool for flooding in rivers with Arduino Nano and ESP8266, the system has successfully programmed the Arduino Nano microcontroller to be able to read sensors by utilizing the sensor library and Arduino IDE software. The sensor needs to be connected to the input output pin on the Arduino Nano so that the sensor data can be read [14]. The sensor tool is able to detect water levels well and accurately. The results of reading sensor data are in accordance with the water level as evidenced by the difference in sensor values during testing at each water level. Sending data from Arduino Nano to ESP8266 and sending data from ESP8266 to the Telegram Application Device also went smoothly, all data was successfully sent. Uploading data to the database was also successful and the data in the database was successfully displayed on people's cellphones. The complete system is cost-effective and has low power consumption. The device can be used for updates and warnings to the community via the Android application [15]. Early notification of flooding in rivers is very helpful for the community in minimizing the impact of flooding. The tests showed that the current system works well, and is useful for practical applications in low-cost flood monitoring systems[16]. From all these tests, it can be said that the software installation on the Arduino board uses a wireless network to ensure that the device changes its performance according to dynamic real-world conditions[17]. The system has successfully monitored the water level that causes the river to overflow onto land which causes flooding in the area around the river.

References

- [1] Bubeck at al. "Societal impacts of flood hazards." *Oxford research encyclopedia of natural Hazard science*. 2017. pp 1-26
- [2] Tapsell, Sue. *Developing a conceptual model of flood impacts upon human health*. Middlesex University, 2009. Pp 1-88
- [3] Yıldız, Sadık, and Mustafa Burunkaya. "Web based smart meter for general purpose smart home systems with ESP8266." *2019 3rd International Symposium on Multidisciplinary Studies and Innovative Technologies (ISMST)*. IEEE, 2019. pp 1-6
- [4] Cameron, Neil, and Neil Cameron. "Microcontrollers." *Electronics Projects with the ESP8266 and ESP32: Building Web Pages, Applications, and WiFi Enabled Devices* (2021):pp 611-639.
- [5] Mutu, Nuba at al. "Low cost, easy-to-use, IoT and cloud-based real-time environment monitoring system using ESP8266 microcontroller." *International Journal of Internet of Things and Web Services* 6 (2021): pp1-44.
- [6] Bo S and Li W,"*International Conference on E-Health Networking Digital Ecosystems and Technologies (EDT) Shenzhen*", 2010, pp 375-378
- [7] Santosa E.S.B.and S. Waluyanti. "Teaching Microcontrollers Using Arduino Nano Based Quadcopter." *Journal of Physics: Conference Series*. Vol. 1413. No. 1. IOP Publishing, 2019. pp 1-8
- [8] Electronicsbot. (2019). Getting to know the IC AVR Microcontroller ATmega328p Atmel 8 Bit Micro Chip Prototype Arduino Robotics Controller. <http://electronicsbot.blogspot.com/2019/06/ic-avr-produk-atmega328p.html>
- [9] Morgan, Elijah J. "HC-SR04 ultrasonic sensor." *Nov* (2014). pp1-6
- [10] Gabriel, Mutinda M., and Kamweru P. Kuria. "Arduino uno, ultrasonic sensor HC-SR04 motion detector with display of distance in the LCD." (2020). pp936-942
- [11] Manurung, Mario Junianto, et al. "Door Security Design Using Fingerprint and Buzzer Alarm Based on Arduino". *Journal of Computer Networks, Architecture and High Performance Computing* 3.1 (2021): pp42-51
- [12] Editorial, "Russia's Zuckerberg launches Telegram, a new instant messenger service," Reuters, August 30, 2013, <http://www.reuters.com/article/idUS74722569420130830>
- [13] Yayla, Ahmet S., and Anne Speckhard. "Telegram: The mighty application that ISIS loves." *International Center for the Study of Violent Extremism* 9 (2017). pp 1-9
- [14] Prasetya, Nyoman Wira, et al. "Design of Water Monitoring System in Aquaponics Based on Arduino Nano and Raspberry Pi." *MATICS: Jurnal Ilmu Komputer dan Teknologi Informasi (Journal of Computer Science and Information Technology)* 15.1 (2023): pp29-42.
- [15] Bachuwar, V. D., et al. "Wsn/wi-fi microchip-based agriculture parameter monitoring using iot." *2018. International Conference on Smart Systems and Inventive Technology (ICSSIT)*. IEEE, 2018. pp214-219.
- [16] Ciuffoletti, Augusto. "Design and implementation of a low cost modularsensor." *2017 IEEE 13th International Conference on Wireless and Mobile Computing, Networking and Communications (WiMob)*. IEEE, 2017. pp17-23

- [17] Sharmila, P., et al. "Realizing Internet Of Things Using Arduino, ESP8266 & Iis Server And Mysql Db For Real-Time Monitoring & Controlling Multiple Fire Alarm Systems Over A Wireless Tcp/Ip Network." *Journal on Software Engineering* 11.2 (2016). pp13-19.
- [18] Putung, Yoice R., et al. "Temperature and Humidity Control System Model using Arduino Nano." *International Journal of Computer Applications* 975: 8887.pp 37-39.
- [19] Rahayu, et al. "Smart Home Design for Controlling Electronic Equipment and Home Security Monitoring Based on the Internet of Things." *Journal of Technology* 6.2 (2019): pp136-148.
- [20] Winarno, Adi, and Mahfud Affandi. "Design and Construction of Smart House Prototype Based Internet of Things (Iot) Using Esp8266." *BEST: Journal of Applied Electrical, Science, & Technology* 4.1 (2022): pp11-14.
- [21] Arnas, Adril, and Solly Aryza. "Study of reliability of smart parking systems based on microcontroller esp 8266 nodemcu." *INFOKUM* 10.1 (2021): pp514-520.
- [22] Nordin, Nadiah, and Omar Abu Hassan. "Integration of IoT on Power Monitoring and Control for House Electrical System." *Advances in Computing and Intelligent System* 1.2 (2019). Pp1-8
- [23] Matos at al. "Technological Innovation for Sustaina bility". *Encyclopedia of Sustainability in Higher Education* (2019): pp1904-1911.
- [24] Dige, Anuradha S., M. Tech Student, and Shrikant R. Tandle. "Air Pollution Monitoring System Based On ESP8266 Using Arduino". *International Journal of Engineering Applied Sciences and Technology, India, ISSN* (2020): 2455-2143. Pp228-235
- [25] Tsyurulnyk, Serhii, et al. "The Climate Control System Using ESP8266 and Arduino IoT Cloud". *CEUR Workshop Proceedings. 2022. Vol. 3309.* pp462-477.

Authors' Profiles



Dwi Mulyani: Born on March 07, 1079 in Sragen City, Central Java, Indonesia. Received a master's degree in Computer Science Amikom Yogyakarta, Yogyakarta, Indonesia in 2015. Currently as a Lecturer at STMIK Banjarbaru, South Kalimantan majoring in Information Systems and Informatics Engineering. Research interests in the application of Computing in the public sector.



Siti Abidah: Born on May 08, 1980 in Martapura City, South Kalimantan, Indonesia. Received a master's degree in Computer Science from Amikom Yogyakarta, Yogyakarta, Indonesia in 2016. Currently a Lecturer at STMIK Banjarbaru, South Kalimantan majoring in Information Systems and Informatics Engineering. Research interests in Data Mining.



Masniah: Born on August 13, 1983 in Kurau City, South Kalimantan, Indonesia. Received a master's degree in Computer Science from Amikom Yogyakarta, Yogyakarta, Indonesia in 2015. Currently a Lecturer at STMIK Banjarbaru, South Kalimantan majoring in Informatics Engineering. Research interests in Data Mining.



Heru Kartika Candra: Born on November 13, 1970 in Tanjung Pinang City, Riau Islands, Indonesia. Received a master's degree in Computer Science at the Sepuluh November Institute of Technology Surabaya, Surabaya, Indonesia in 2000. Currently a Lecturer at the Banjarmasin State Polytechnic, South Kalimantan majoring in Computer Accounting. Research interests in the application of computers to society.

How to cite this paper: Dwi Mulyani, Siti Abidah, Masniah, Heru Kartika Candra, "Flood Early Warning in Rivers Based on ESP8266 Microcontroller and Arduino Nano", International Journal of Engineering and Manufacturing (IJEM), Vol.15, No.5, pp. 18-30, 2025. DOI:10.5815/ijem.2025.05.02