

Available online at <http://www.mecspress.net/ijwmt>

Mutual Coupling Reduction between H Shaped Compact MIMO Antenna for WLAN Application

Pratima.C.Nirmal^{a,*}, Anil Nandgaonkar^a, Sanjay Nalbalwar^a

^a*Department of Electronics & Telecommunication, DBATU, Lonere, Raigad – 402103, India.*

Received: 19 May 2017; Accepted: 16 June 2017; Published: 08 November 2017

Abstract

A simple compact H shaped MIMO antenna for WLAN application at resonating frequency 5.8 GHz is propose in this paper. The center to center spacing between closely placed H shaped MIMO antenna is $0.311\lambda_0$. The mutual coupling between the proposed antenna is reduced by using dumbbell shaped DGS at the center of the groundplane. These dumbbell shape defect act as bandstop filter because of its inductance and capacitance effect, helps to suppress the surface wave propagation of waves. The filter characteristic of the dumbbell shaped DGS is studied to achieve isolation over the 5.725-5.875 GHz frequency band. Further the parametric study such as length, width and the spacing of dumbbell shaped DGS is optimized and studied in order to achieve good isolation among the MIMO antenna elements. The proposed MIMO structure is fabricated on low cost FR4 substrate having thickness of 1.6mm and the overall dimension of MIMO antenna is 40mm x 24 mm leading to compact size of antenna. The mutual coupling reduces from 24 dB to 34 dB by placing dumbbell shaped DGS. The envelope correlation coefficient for the proposed antenna is below less than 0.04 dB for the operating frequency band. The proposed H shaped MIMO antenna is tested and the measured result follows the simulation results. Therefore the proposed antenna is a good candidate for WLAN application.

Index Terms: DGS (Defected Ground Structure), Mutual coupling, ECC (Envelope correlation coefficient), Isolation, Parasitic Elements, EBG (Electromagnetic Bandgap Structure)

© 2017 Published by MECS Publisher. Selection and/or peer review under responsibility of the Research Association of Modern Education and Computer Science

1. Introduction

Due to rapid increase in the demand of capacity and data rate in wireless communication systems, MIMO antenna came in to existence. Earlier, the SISO (Single Input and Single output) system in which single antenna

* Corresponding author.

E-mail address: pratima.nirmal@gmail.com

was employed to transmit and receive the data efficiently was employed. But this system cannot fulfill the demands of higher data rate due to its limited bandwidth handling capacity and they also suffer from multipath fading which reduces the signal to noise ratio level of the received signal [1-2]. The MIMO antennas use many antenna at the transmitter and at the receiver side to increase the capacity and throughput of system. The capacity of channel is well utilized in MIMO antenna without using extra spectrum and radiation power [3]. Besides these MIMO antennas uses various diversity schemes such as polarization diversity, pattern diversity and space diversity to overcome the multipath fading. Although MIMO antenna has several advantages, the challenge lies in the designing of efficient MIMO antennas [4]. The MIMO antenna design should be compact, have good impedance bandwidth, less VSWR, less mutual coupling and good radiation properties over the operating frequency band so that it can be easily integrate and can be efficiently used for many applications such as WLAN, Wi-Fi, WI-Max, LTE, Bluetooth, UWB etc.

Many researchers had studied different technique such as parasitic elements, EBG structure, metamaterial, DGS, etc to reduce the mutual coupling between MIMO antenna elements [5-18]. Electromagnetic bandgap structure (EBG) also known as photonic bandgap structure is widely used for improving the isolation between MIMO antenna elements. They have bandgap characteristic to suppress the surface wave. The design of EBG structure are done in such a way that the resonating frequency of bandgap should coincide with the operating frequency band of MIMO antenna so as to have huge isolation over the operating bandwidth [5-6]. The mushroom like EBG structure has been placed in between E and H coupled microstrip array to improve the isolation by 8 dB [7]. The dispersion diagram of EBG structure showing the suppression of surface wave is studied by FDTD simulation. An S shaped EBG structure is placed in between MIMO antenna having dimension of 38 mm × 68 mm to improve the isolation by 20 dB [8]. The bandgap of mushroom and fork type EBG structure for frequency 8.5-11.5 GHz and 9.1- 10.7 GHz is studied and they are employed in microstrip array for reduction of mutual coupling of about 60 dB [9]. The EBG increases the complexity in designing and fabrication process of MIMO antenna.

Metamaterial has been used in recent years to reduce the mutual coupling in MIMO antenna elements [10-13]. Metamaterial are basically artificially materials that have negative permeability and permittivity which can be realized in the form of split ring resonator (SRR) or meander lines. A compact PIFA antenna fabricated on FR-4 substrate with SRR structure is used in between to lower the mutual coupling by 6 dB [10]. The isolation of 45 dB is improved by modified SRR in shape of circle between the dielectric resonator antennas working at 60 GHz frequency [11]. Complementary Split ring resonator comprises of annular rings with slit at opposite end is employed to lower the mutual coupling between MIMO antenna [12]. This annular ring contributes to negative permeability and negative permittivity which improves the isolation. The mutual coupling between meander line antennas at 2.4 GHz is reduced by using labyrinth SRR to have improved isolation of 45 dB and envelope correlation coefficient of 55 dB [13]. The SRR thus used is difficult to design and incorporate between MIMO antenna elements. The use of parasitic elements has been reported in [14-15] to improve the isolation.

U shaped parasitic element is placed between suspended MIMO antennas at 2.44 GHz frequency to lower the mutual coupling by 38 dB [14]. The advantage of using parasitic element is its simple to fabricate. Further F shaped parasitic element which is fabricated on the other side of substrate has been reported for dual band MIMO antenna operating at 2.5 GHz and 5.2 GHz frequency [15]. The parasitic patch is electromagnetically coupled to antenna and it also helps to improve the gain of the antenna. Besides above all method for the reduction of mutual coupling, defected ground structure is widely used because it is simple to fabricate with less complexity [16-20]. Defected ground structure introduces defect in the ground plane which disturb the current distribution of the ground plane thus affecting the resonant frequency of the antenna and improving the isolation. A MIMO antenna with edge to edge spacing of 0.260λ operating at frequency 9.1 GHz is designed [16]. Three rectangular slit as a defects is introduced in the ground plane to improve the isolation by 35 dB. The dimension and position of slits has been optimized to have huge isolation over the operating band. With help of stub and small strip, isolation between compact square monopole antennas is improved [17]. The monopole antenna has wide bandwidth (3.1-10.6 GHz) with envelope correlation coefficient of 0.2 dB as well as stable

radiation pattern over the bandwidth. A new tree shape DGS having three branches has been incorporated in between UWB band antennas to have $S_{21} < -16$ dB over the entire band [18]. The overall dimension of UWB antenna is 35 mm x 40 mm and is fabricated on taconic dielectric substrate.

A PIFA antenna with side to side spacing of 10 mm is designed on FR-4 Substrate at frequency 2.31 GHz [19]. The isolation of about more than 20 dB between these elements is achieved by placing number of slits in the ground plane. This proposed technique can be applied to more than three or four antenna elements. Two elliptical patches placed at an angle of 45^0 with respect to each other with the supplementary ground are proposed [20]. The slit is etched at the center of the groundplane, thus improving the isolation by 25 dB at 2.4 GHz. The design is easy to fabricate and have good impedance bandwidth with improved radiation characteristic. A compact multiband U shaped monopole for WLAN, Wi-MAX and lower UWB applications has been reported [21]. Mutual coupling less than -18 dB is achieved between multiband MIMO antenna is obtained by incorporating three dumbbell shaped DGS at the center of the ground plane. Reduction of mutual between closely placed MIMO antennas at 5.8 GHz is done by using transmission line [22]. The parameter of transmission line is optimized to have a isolation of 48 dB.

In this paper, a compact H shaped MIMO antenna has been designed. To improve the isolation between H shaped compact MIMO antennas, a dumbbell shaped DGS is used. This dumbbell shape defect act as bandstop filter because of its inductance and capacitance effect, helps to suppress the surface wave propagation and hence improve the isolation. The filter characteristic of the dumbbell shaped DGS is studied to obtain isolation over the 5.725-5.875 GHz frequency band. Further the parametric study such as length, width and the spacing of dumbbell shaped DGS is optimized and studied in order to achieve good isolation among the MIMO antenna element. The mutual coupling reduces from 20 dB to 34 dB by placing dumbbell shaped DGS.

2. Antenna Design and Results

A compact H shape antenna with center to center spacing of $0.311\lambda_0$ is designed in this paper as shown in Fig.1 (b). The antenna is fed by coaxial probe and constructed on FR-4 substrate having thickness of 1.6 mm and dielectric constant of 4.4. The simulated $S_{11} < -10$ dB over 5.725-5.875 GHz frequency but S_{21} is still high leading to mutual coupling between the H shaped antenna elements. To improve the isolation between these two H shape MIMO antenna elements, a dumbbell shaped DGS is introduced in the ground plane as shown in Fig.1(c). This dumbbell shaped DGS increases the effective inductance and capacitance. It acts as a band stop filter at frequency 5.8 GHz which block the current to propagate from one to another antenna element. The step by step evolution of proposed H shaped MIMO antenna is as shown in Fig.1. Initially a rectangular shaped microstrip antenna has been designed using equation (1), (2), (3) and (4) to have more fringing fields and good radiation efficiency [23]. The width can be calculated by using (1):

$$w = \frac{v_o}{2f_r} \times \sqrt{\frac{2}{\epsilon_r + 1}} \quad (1)$$

where v_o is velocity of light, ϵ_r is substrate dielectric constant and f_r is resonant frequency of antenna.

The length of antenna can be calculated by following formula:

$$L = \frac{v_o}{2f_r \sqrt{\epsilon_{reff}}} - 2\Delta L \quad (2)$$

where

(i) ϵ_{reff} is effective dielectric constant which is obtained by using (3) as follows:

$$\epsilon_{r_{eff}} = \frac{\epsilon_r + 1}{2} + \frac{\epsilon_r - 1}{2\sqrt{1 + \frac{12h}{W}}} \quad (3)$$

where h is thickness of the substrate
(ii) ΔL can be calculated as:

$$\Delta L = 0.412 h \frac{(\epsilon_{eff} + 0.3) \left(\frac{W}{h} + 0.264\right)}{(\epsilon_{eff} - 0.258) \left(\frac{W}{h} + 0.8\right)} \quad (4)$$

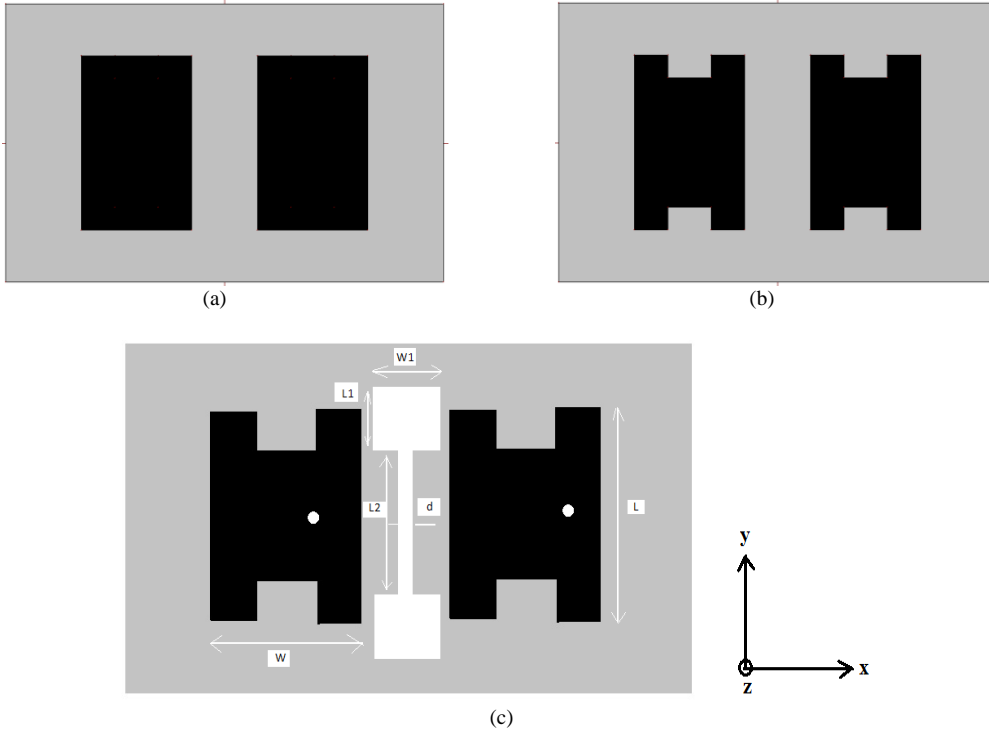

Fig.1. Evolution of Proposed structure (a) Antenna 1 (b) Antenna 2 and (c) proposed Antenna Structure

Then, a MIMO antenna consisting of two rectangular patches with center to center spacing of 15 mm is designed on common groundplane leading to Antenna 1. Antenna 2 is formed by cutting a rectangular slot from the top and bottom of rectangular MIMO antenna leading to H shaped MIMO antenna. These slots are introduced to increase the total current length on the surface of the patch antenna and thus it will increase the impedance bandwidth of the H shaped MIMO antenna. The antenna is made to resonant at 5.8 GHz frequency for WLAN application. The dimension of the proposed MIMO antenna is listed in Table no.1.

Table.1. Dimension of proposed Antenna

| N | Parameter | Dimension in mm |
|---|---------------------|-----------------|
| 1 | Length of patch (L) | 10.1 mm |
| 2 | Width of patch (W) | 15 mm |
| 3 | Substrate Height | 1.59 mm |
| 4 | L1 | 5mm |
| 5 | L2 | 12mm |
| 6 | W1 | 5 mm |
| 7 | Overall dimension | 40 mm x 24 mm |

The simulated H shaped MIMO antenna with and without dumbbell shaped DGS as shown in Fig. 2(a) and 2 (b) respectively. It has been observed that MIMO antenna without DGS has huge mutual coupling across the operating frequency 5.725- 5.875 GHz band which will lead to high signal interference and losses, thus it is not suitable for WLAN application. Hence, to lower the mutual coupling and to improve the isolation, a dumbbell shaped DGS is introduced in the ground plane. By introducing a dumbbell shaped DGS, the mutual coupling significantly reduces to 34 dB from 24 dB at 5.8 GHz as shown in the Fig. 2(b) respectively.

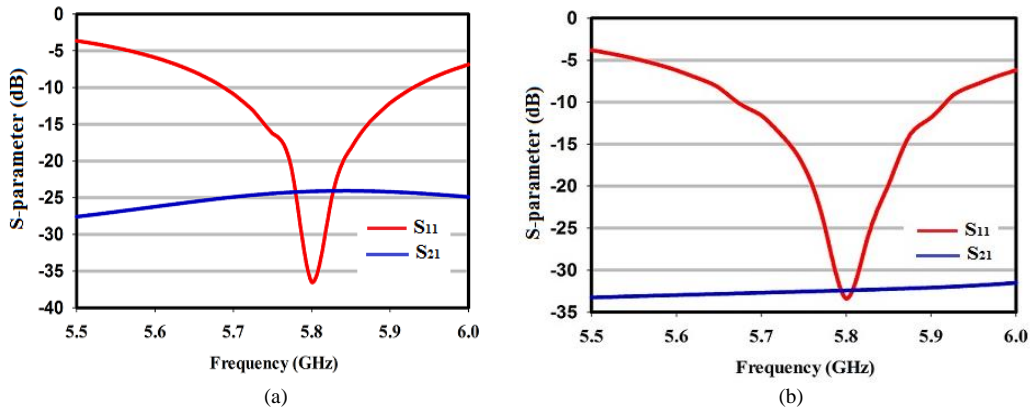

Fig.2. Simulated S Parameter (a) without DGS and (b) with DGS

The dumbbell shaped DGS consist of square head of $L1 \times W1 \text{ mm}^2$, length between the dumbbell 'L2' and gap 'd' between the dumbbell as shown in Fig.3(a). These DGS is introduced in the middle of the groundplane to have huge isolation. The equivalent circuit of dumbbell shape DGS is as shown in the dotted box in Fig. 3(b). The equivalent circuit of dumbbell shaped DGS consists of LC resonator circuit with inductance in parallel with capacitance [24]. This circuit has resonance frequency that depends on the value of L and C. The value of L and C depend on the area of square head and gap (d) respectively. The values of inductance (L) and capacitance (C) can be obtained by using following formula [25]:

$$L = \frac{1}{4\pi^2 f_0^2 C} \quad (5)$$

$$C = \frac{f_c}{2Z_0} \cdot \frac{1}{2\pi(f_0^2 - f_c^2)} \quad (6)$$

where f_0 is resonant frequency and f_c is cutoff frequency of DGS respectively.

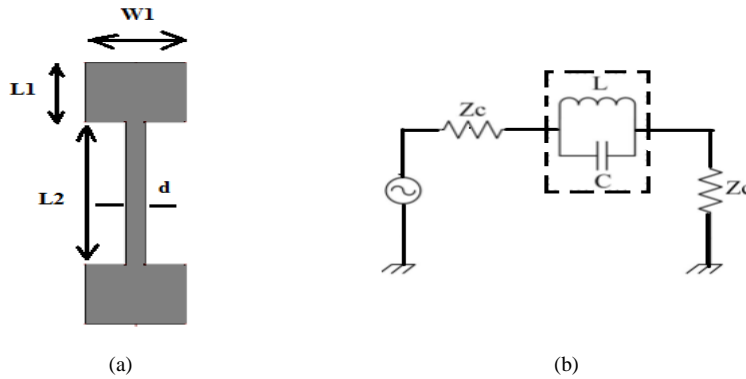

Fig.3. (a) Dumbbell DGS and (b) its equivalent circuit

The bandstop characteristic of proposed DGS can be studied by placing $50\ \Omega$ microstrip line above it as shown in Fig. 4(a). The S-parameter i.e. transmission and reflection characteristic of proposed DGS is as shown in the Fig. 4(b). It indicates that the proposed DGS has zero transmission characteristics over the operating frequency band (5.725-5.875 GHz). The dumbbell shape DGS thus design act as a bandstop filter over the wide band (5.725-5.875 GHz).

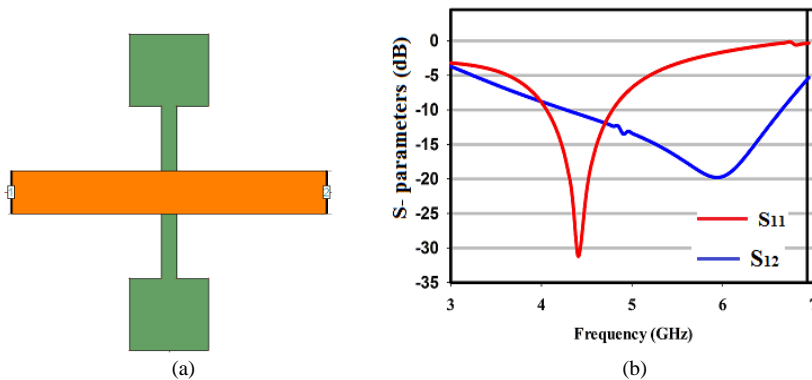

Fig.4. (a) Proposed DGS with $50\ \Omega$ transmission line and (b) its simulated S parameter

The feature of suppression of current is well explained by the surface current distribution. The surface current distribution of MIMO antenna with and without DGS at 5.8 GHz is as shown in Fig. 5(a) and 5.(b) respectively. The 1st port is excited by current and 2nd port is terminated by load of 50 ohms. The large amount of current is trapped by dumbbell shaped DGS and thus negligible amount of current is introduced in second MIMO antenna element as shown in Fig.5(b).

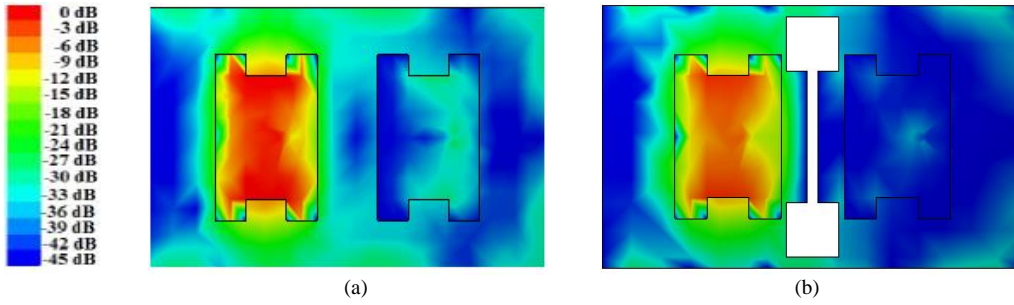

Fig.5. Surface current distribution at 5.8 GHz (a) without DGS and (b) with DGS

When DGS is introduced in the ground plane, slow wave effect of DGS shifts the resonating frequency of antenna to lower side. The parameter L_1 , L_2 , W_1 and d of dumbbell shaped DGS is optimize for improving the isolation of proposed antenna. By etching dumbbell shape defect in ground, effective series inductance increases which shift the resonating frequency of antenna to lower side. The head dimension ($L_1 \times W_1$) of the DGS is varied by keeping gap (d) constant. The head of dumbbell ($L_1 \times W_1$) contributes to inductance effect whereas the gap (d) contributes to conductance effect. The L_1 and W_1 is varied from 4 mm to 6 mm, the isolation appears at various frequencies as shown in Fig. 6 and Fig.7. The isolation of -34 dB at a resonant frequency 5.8 GHz is obtained for the length $L_1 = 5$ mm and width $W_1 = 5$ mm. Similarly $L_2 = 12$ mm is optimum value for low mutual coupling as shown in Fig.8. The gap d is varied by keeping L_1 and W_1 constant, thus series inductance is kept constant for all cases. With an increase in the gap distance, there is decrease in effective capacitance and thus increases the cut-off frequency of LC circuit. The d is varied from 1.5 mm to 2.5 mm as shown in Fig.9 and the optimum value of d for good isolation is 2 mm.

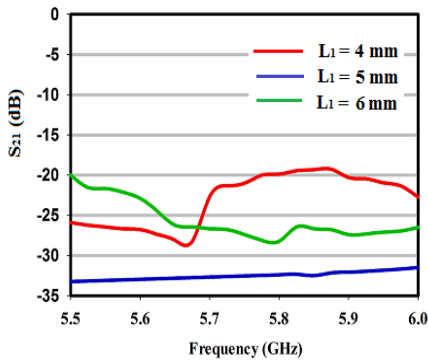

Fig.6. Simulated S_{21} for different value of L_1

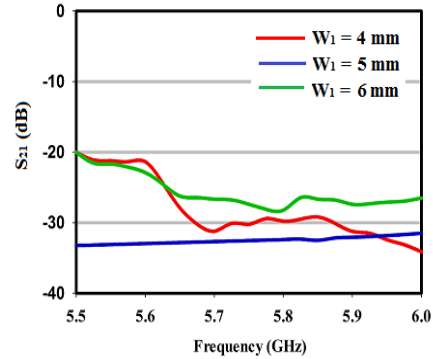

Fig.7. Simulated S_{21} for different value of W_1

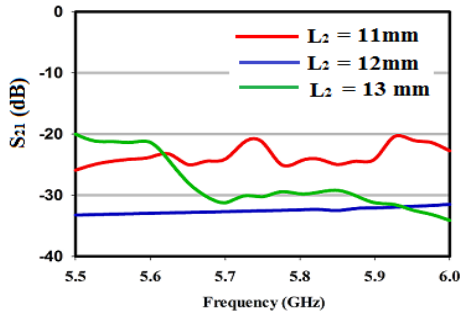

Fig.8. Simulated S_{21} for different value of L_2

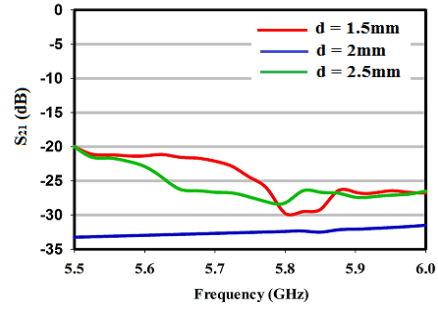

Fig.9. Simulated S_{21} for different value of d

The radiation pattern of proposed MIMO antenna is as shown in Fig.10. It shows that antenna is directional with cross polarization level and side lobe level less than -20 dB. The plot of gain variation v/s Frequency is shown in Fig.11. The graph shows the gain variation of less than 1 dB over the operating frequency band.

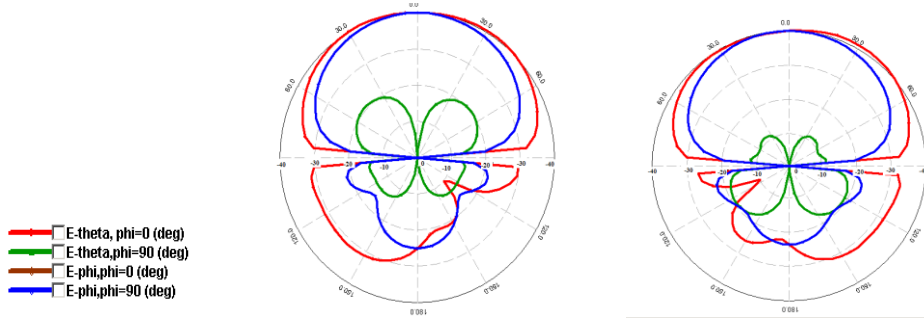

Fig.10. Radiation pattern at frequency 5.8 GHz (a) when port 1 is excited (b) when port 2 is excited

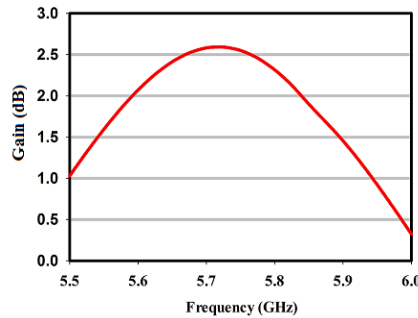

Fig.11. Gain variation v/s Frequency

3. Fabricated Antenna & Measured Results

A compact H shaped MIMO antenna is constructed on FR-4 substrate as shown in Fig 12 and is tested using Agilent 9916 A network analyzer. The comparison of measured and simulated S-parameter is shown in Fig.13. There is slight variation in measured and simulated result due to fabrication error and losses in conductor and connector.



Fig.12. Fabricated antenna

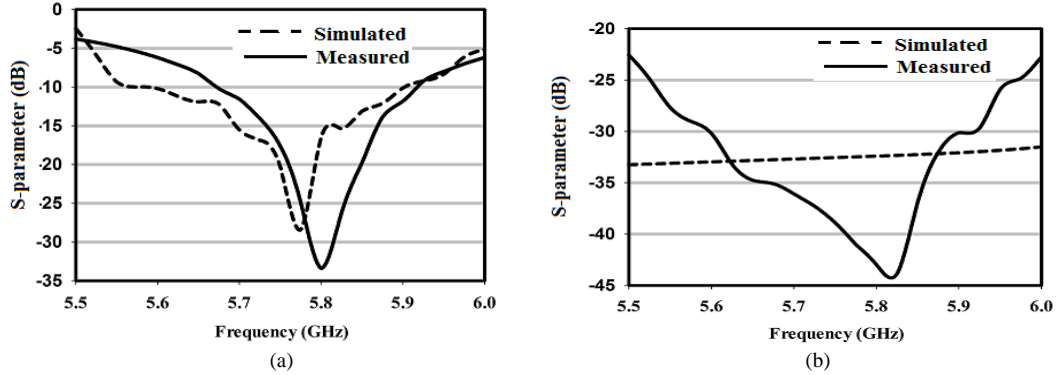

Fig.13. Measured and Simulated (a) S_{11} and (b) S_{21} of the proposed structure

The MIMO antenna performance can be shown by envelope correlation coefficient. It is the measure of how two antennas are well isolated from each other. The ECC should be less than 0.5 dB for MIMO applications. The envelope correlation coefficient can be calculated using (7) as follows [26]:

$$\rho = \frac{|S_{11}^* S_{12} + S_{21}^* S_{22}|}{|(1-|S_{11}^2|-|S_{21}^2|)(1-|S_{22}^2|-|S_{12}^2|)} \tag{7}$$

The correlation coefficient thus obtained for the proposed antenna is below 0.04 dB as shown in Fig.14

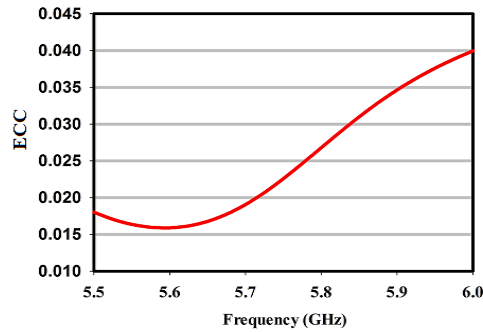

Fig.14. Envelope Correlation coefficient v/s frequency

4. Conclusions

A compact H shaped MIMO antenna with an improved is proposed in this paper. The dumbbell shaped DGS is introduced in the center of the groundplane to improve the isolation. The parameters of dumbbell shaped DGS is optimized to have good isolation among the antenna element. The proposed design is simple, low cost and compact. The radiation pattern is stable and ECC < 0.04 dB is achieved. Hence, the proposed antenna is suitable for WLAN application at resonating frequency 5.8 GHz. The proposed technique can be extend for improving the isolation in more than two elements of MIMO antenna.

References

- [1] Michael A. Jensen and Jon W. Wallace, "A review of antennas and propagation for MIMO wireless communications," *IEEE Transactions on Antennas and Propagation*, Vol. 52, No. 11, 2810-2824, Nov. 2004.
- [2] Lizhong Zheng and D. N. C. Tse, "Diversity and multiplexing: a fundamental trade off in multiple-antenna channels," *IEEE Transactions on Information Theory*, Vol. 49, No. 5, 1073-1096, May. 2003.
- [3] D. Gesbert, M. Shafi, Da-shan Shiu, Peter J. Smith, and Ayman Naguib, "From theory to practice: An overview of MIMO space-time coded wireless systems," *IEEE Journal on Selected Areas in Communications*, Vol. 21, No. 3, 281-302, Apr. 2003.
- [4] Atif Jamil, Mohd Zuki Yusoff and Noorhana Yahya, "Current Issues and Challenges of MIMO Antenna Designs", *IEEE conference on Intelligent and Advanced Systems (ICIAS)*, Kuala Lumpur Malaysia, pp. 1-5, June. 2010.
- [5] Jing Liang, H. Y. D. Yang, "Microstrip Patch Antennas on Tunable Electromagnetic Band-Gap Substrates", *IEEE Transactions on Antennas and Propagation*, vol.57, pp. 1612-1617, June. 2009.
- [6] Nabilah Ripin, Robiatun Adayiah Awang, Ahmad Asari Sulaiman, Noor Hasimah Baba and Suhaila Subahir "Rectangular Microstrip Patch Antenna with EBG Structure", *IEEE Student conference on Research and Development (SCORED)*, Pulau Pinang, 2012, pp. 266 – 271.
- [7] Fan Yang and Y. Rahmat-Samii, "Microstrip antennas integrated with electromagnetic band-gap (EBG) structures: a low mutual coupling design for array applications", *IEEE Transactions on Antennas and Propagation*, Vol.55, pp.2936 - 2946, Jul.2003.
- [8] A. Veeramani, Afsane Saeed Arezomand, J. Vijayakrishnan and Ferdows B. Zarrabi, "Compact S-Shaped EBG Structures for Reduction of Mutual Coupling", *2015 Fifth International Conference on Advanced Computing & Communication Technologies*, Haryana, 2015, pp. 21-25.
- [9] Cuong Tran Manh, Xiaoke Han, H. Hafidallah Ouslimani, Alain Priou, Aurélien Marteau and Gérard Collignon, "Reduction of the coupling between Microstrip Arrays Antennas Using High Impedance Surface (HIS) Structures", *2010 European Microwave Conference (EuMC)*, Paris, pp.1453-1456, Sept.2010.
- [10] Soon Ho Hwang, Tae Sik Yang, Joon Ho Byun and Austin S. Kim, "Reduction of Mutual Coupling between Closely-Packed Antenna Elements with Split Ring Resonator (SRR)" *2010 International Conference on Microwave and Millimeter Wave Technology (ICMMT)*, Chengdu, 2010, pp.1873-1875.
- [11] Abdolmehdi Dadgarpour, Behnam Zarghooni and Tayeb A. Denidni, "Mutual-Coupling suppression for 60 GHz MIMO Antenna using Metamaterials", *2015 IEEE International Symposium on Antennas and Propagation & USNC/URSI National Radio Science Meeting*, Vancouver, BC, 2015, pp. 422-423.
- [12] Vu Van Yem, Pham Van Chi and Bernard Journet, "Novel MIMO Antenna Using Complementary Split Ring Resonator (CSRR) For LTE Applications.", *2012 International Conference on Advanced Technologies for Communications (ATC)*, Hanoi, 2012, pp. 222-226.

- [13] Qing-Le Zhang, Yu-Ting Jin, Jia-Qi Feng and Xin Lv, "Mutual Coupling Reduction of Microstrip Antenna Array Using Metamaterial Absorber", IEEE MTT-S International Microwave Workshop Series on Advanced Materials and Processes for RF and THz Applications (IMWSAMP), Suzhou, 2015, pp. 1-3.
- [14] Saeed Farsi, Hadi Aliakbarian, Dominique Schreurs, Bart Nauwelaers and Guy A. E. Vandenbosch "Mutual Coupling Reduction Between Planar Antennas by Using a Simple Microstrip U-Section", IEEE Antennas and Wireless Propagation Letters, Vol. 11, pp. 1501 – 1503, Dec 2012.
- [15] Komal A. Kalamkar, Sachin S. Khade and S. L. Badjate "A 4-shaped MIMO Antenna for WLAN Application", Communications and Signal Processing (ICCSP), 2015 International Conference, Melmaruvathur, 2015, pp.1831 – 1834.
- [16] Asieh Habashi, Javad Nourinia and Changiz Ghobadi, "A Rectangular Defected Ground Structure (DGS) for Reduction of Mutual Coupling Between Closely-Spaced Microstrip Antennas", 20th Iranian Conference on Electrical Engineering (ICEE2012), Tehran, 2012, pp.1347 – 1350.
- [17] Li Liu, S. W. Cheung and T. I. Yuk, "Compact MIMO Antenna for Portable Devices in UWB Applications", IEEE Transactions on Antennas and Propagation, Vol.61, no. 8, pp. 4257 – 4264, May 2013.
- [18] Shuai Zhang, Zhihong Ying, Jiang Xiong and Sailing He "Ultrawideband MIMO/Diversity Antennas With a Tree-Like Structure to Enhance Wideband Isolation", IEEE Antennas and Wireless Propagation Letters, Vol. 8, pp. 1279 – 1282, Nov.2009.
- [19] Chi-Yuk Chiu, Chi-Ho Cheng, Ross D. Murch, Corbett R. Rowell "Reduction of Mutual Coupling Between Closely Packed Antenna Elements", IEEE Transactions on Antennas and Propagation, Vol.55, pp. 1732- 1738, June. 2007
- [20] kyu Kim, Chang won Jung, Yong jin Kim and Young eil Kim, "Low-Profile Wideband MIMO Antenna With Suppressing Mutual Coupling Between Two Antennas", Microwave and Optical Technology Letters, Vol. 50, no. 5, pp.1336–1339, May 2008.
- [21] Sachin S. Khade, S.L.Badjate, "A Compact Multiband U Shape MIMO Antenna for Wireless Application", IJ. Wireless and Microwave Technologies, Vol.5, no.5, pp. 61-71, 2016.
- [22] Z. Wang, "Reducing Mutual Coupling of Closely Space Microstrip Antennas for MIMO Application at 5.8 GHz", Journal of Electromagnetic Waves and Applications, vol.25, 399-409.
- [23] Girish kumar and K. P. Ray, Broadband Microstrip Antennas, Artech House, Norwood, MA, 2003.
- [24] Liu, H., Z. Li, and X. Sun, "Compact defected ground structure in Microstrip technology," Electronics Letters, Vol. 41, No. 3, 132– 134, 2005.
- [25] Li, G. H., X. H. Jiang, and X. M. Zhong, "A novel defected ground structure and its application to a low pass filter," Microwave and Optical Technology Letters, Vol. 48, No. 9, 453–456, 2006.
- [26] S.Blanch, J.Romeu, and I. Corbella, "Exact representation of antenna system diversity performance from input parameter description," Electron. Letter, Vol. 39, No. 9, 705–707, May 2003.

Authors' Profiles



Pratima.C.Nirmal was born in India in 1990. She received her B.E degree in Electronics and Telecommunication engineering from Mumbai University, India in 2011 and M.E degree from Mumbai University in 2013 and is currently working toward the PhD degree in Electronics and telecommunication engineering at Dr. Babasaheb Ambedkar Technological University, Lonere, India. Her research interests includes the design of MIMO antennas, Monopole antenna, and filters



Dr. A.B.Nandgaonkar has received B.E. (Electronics & Telecomm. Engineering) from Marathwada University, Aurangabad and M. E. (Electronics) from Dr. B.A.M.U. Aurangabad. He has completed Ph.D. in Electronics & Telecommunication. Engineering from Dr. B.A.T.U. Lonere. His research Interests includes Antenna and Propagation, Microwave Engineering, EMI/EMC and Optical Communication. He had received National Merit Scholarship.



Sanjay Nalbalwar has received B.E. (CSE) in 1990 and M.E (Electronics) in 1995 from SGGGS College of Engineering and Technology, Nanded, MS. He has completed Ph.D. from IIT Delhi in the year 2008. He has around 22 years of teaching experience and is working as a Professor & Head of Electronics and Telecommunication Engineering Department at Dr.BabasahebAmbedkar Technological University, Lonere, Raigad, Maharashtra State (India). His area of interest includes Multirate Signal Processing and Wavelet, Stochastic Process Modeling. He has to his credit around 150 papers in national and international conferences and 50 papers in the international journals. He is member of professional bodies like ISTE, IETE, IEEE, CSIIE. He is also working on various research projects in the area of biomedical signal processing, signal representation, signal matched wavelets, smart grid. He guided about 50 M.Tech projects and about 200 B.Tech. projects and presently guiding 6 Ph.D. students.

How to cite this paper: Pratima.C.Nirmal, Anil Nandgaonkar, Sanjay Nalbalwar," Mutual Coupling Reduction between H Shaped Compact MIMO Antenna for WLAN Application", International Journal of Wireless and Microwave Technologies(IJWMT), Vol.7, No.6, pp. 46-57, 2017.DOI: 10.5815/ijwmt.2017.06.05