

Fuzzy Controller Design using FPGA for Sun Tracking in Solar Array System

Basil M. Hamed

Electrical Engineering Department, Islamic University of Gaza, Gaza, Palestine
Email: bhamed@iugaza.edu

Mohammed S. El-Moghany

Electrical Engineering Department, Islamic University of Gaza, Gaza, Palestine
Email: elmoghany@hotmail.com

Abstract— The output power produced by high-concentration solar thermal and photovoltaic systems is directly related to the amount of solar energy acquired by the System, and it is therefore necessary to track the sun's position with a high degree of accuracy. This paper presents sun tracking generating power system designed and implemented in real time. A tracking mechanism composed of photovoltaic module, stepper motor ,sensors, input/output interface and expert FLC implemented on FPGA, that to track the sun and keep the solar cells always face the sun in most of the day time. The proposed sun tracking fuzzy controller has been tested using Matlab/Simulink program; the simulation results verify the effectiveness of the proposed controller and shows an excellent result.

Index Terms— Fuzzy Control, Sun Tracking, Photovoltaic System, FPGA

I. INTRODUCTION

Renewable energy sources play an important role in electric power generation. There are various renewable sources which used for electric power generation, such as solar energy, wind energy, geothermal etc [1]. Solar Energy is a good choice for electric power generation, since the solar energy is directly converted into electrical energy by solar photovoltaic modules [2]. These modules are made up of silicon cells [3]. Many such cells are connected in series to get a solar PV module. The current rating of the modules increases when the area of the individual cells is increased, and vice versa. When many such PV modules are connected in series and parallel combinations we get solar PV arrays, that suitable for obtaining higher power output.

The applications for solar energy in recent years are increased rapidly, and that need to improve the materials and methods used to harness this power source [4]. Main factors that affect the efficiency of the collection process are solar cell efficiency, intensity of source radiation and storage techniques. The efficiency of a solar cell is limited by materials used in solar cell manufacturing. It is particularly difficult to make considerable improvements in the performance of the cell, and hence restricts the efficiency of the overall collection process. Therefore, the increase of the intensity of radiation received from the

sun is the most attainable method of improving the performance of solar power. There are three major approaches for maximizing power extraction in solar systems. They are sun tracking, maximum power point (MPP) tracking or both [5]. These methods need intelligent controllers such as fuzzy logic controller or conventional controller such as PID controller.

The advantage of the fuzzy logic control is that it does not strictly need any mathematical model of the plant. It is based on plant operator experience, and it is very easy to apply. Hence, many complex systems can be controlled without knowing the exact mathematical model of the plant [6]. In addition, fuzzy logic simplifies dealing with nonlinearities in systems [7]. The good thing about fuzzy logic control is that the linguistic system definition becomes the control algorithm. A very popular method of implementing fuzzy controller is using a general-purpose microprocessor or microcontroller. Microprocessor based controllers are more economical, but often face difficulties in dealing with control systems that require high processing and input/output handling speeds [8]. Rapid advances in digital technologies have given designers the option of implementing a controller on a variety of Programmable Logic Device (PLD), Field Programmable Gate Array (FPGA), etc. FPGA is suitable for fast implementation controller and can be programmed to do any type of digital functions. An FPGA has the ability to operate faster than a microprocessor chip. Because of the flexibility of the FPGA, additional functionality and user interface controls can be incorporated into the FPGA minimizing the requirement for additional external components [9]. FPGAs are programmed using Very High Speed Integrated Circuit hardware description language (VHDL) and a download cable connected to a host computer. Once they are programmed, they can be disconnected from the computer, and it will be running as stand-alone device. The FPGAs can be programmed while they run, because they can be reprogrammed in the order of microseconds. This short time means that the system will not even sense that the chip was reprogrammed [10]. Applications of FPGAs include industrial motor drivers, real time systems, digital signal

processing, aerospace and defense systems, medical imaging, computer vision, speech recognition, cryptography, computer hardware emulation and a growing range of other areas.

The hardware implementation of fuzzy logic controller (FLC) on FPGA is very important because of the increasing number of fuzzy applications requiring highly parallel and high speed fuzzy processing. A significant advantage of this FLC is that it has been coded in VHDL and programmed into a single field programmable gate array (FPGA) [11]. Because this reduces the number of electronic components used to implement the controller, it enables redundancy by having multiple copies/images of the code, and yields robustness as a controller that has multiple systems capability [12]. So the FLC may implement on FPGA and used to moves a motor attached to the solar panel to keep it toward the sun all the day. Then we must choose the kind of the motor as appropriate with the controlled system.

Many applications related to positioning systems are being implemented with stepper motors. It has some applications in Robotics, Computer peripherals, Industrial servo quality drivers and so on. One of the main advantages of stepper motors is the strong relation between electrical pulses and rotation discrete angle steps [13].

A. Sun Tracker

Solar tracking system uses a stepper motor as the drive source to rotate the solar panel as shown in Figure 1. The position of the sun is determined by using a tracking sensor, the sensor reading is converted from analog to digital signal, and then it passed to a fuzzy logic controller implemented on FPGA. The controller output is connected to the driver of the stepper motor to rotate PV panel in one axis until it faces the sun.

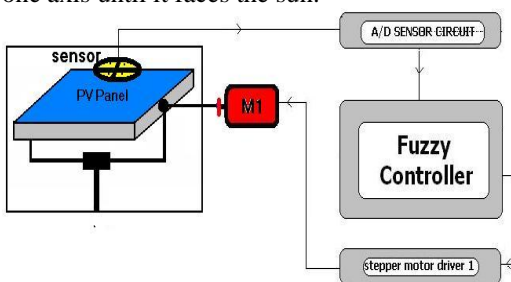

Figure 1. Block Diagram of Sun Tracker System

II. SENSORS

There are two sensors used in the sun tracking system: photo sensor, and position sensor.

A. Photo Sensor

Light dependent resistor (LDR) is used to construct the sensor, because it is the most reliable sensor that can be used for light sensing. LDR is basically a resistor whose resistance varies with intensity of light, so more intensity gives less resistance. Different LDR sensors available in the market are, the biggest size is used to construct the

sensor because the more area of the sensor mean more its sensitivity or less time taken for output to change when input changes.

Tracking Sensor Design

The tracking sensor is composed of two similar LDR sensors, which are located at the east, west, or south, and north to detect the light source intensity. The LDR sensor forms a 45° angle with the light source. At the LDR sensor positions, brackets isolate the light from other orientations to achieve a wide-angle search and quickly determine the sun's position.

To sense the position of Sun in one axe say east/west, two LDR sensors are mounted on the solar panel and placed in an enclosure. It has a response which is similar to the human eye. The east and west LDR sensors compare the intensity of received light in the east and west. When sun's position shifts, here the light source intensity received by the sensors are different, the system obtains signals from the sensors' output voltage in the two orientations. The system then determines which sensor received more intensive light based on the sensor output voltage value interpreted by voltage type A/D converter. The system drives the step motor towards the orientation of this sensor. If the output values of the two sensors are equal, the output difference is zero and the motor's drive voltage is zero, which means the system has tracked the current position of the sun.

B. Position Sensor

Position sensor used to determine the location of the PV panel to prevent the panel from the impact when it reaches the edges, and to get the PV panel to the starting point at the night. This sensor used a variable resistor (potentiometer) located on the rotor of the motor and rotate with it, and the value of the resistor (R) varies with the rotation as shown in Figure 2. When the position sensor reaches the values at the PV at the edges, the controller stopped the motor and immune it from rotating in that direction. At the night the LDRs sensors are very dark light and their values are very big, in this situation the controller go to night subroutine to rotate the PV panel until the position sensor has the starting point value.

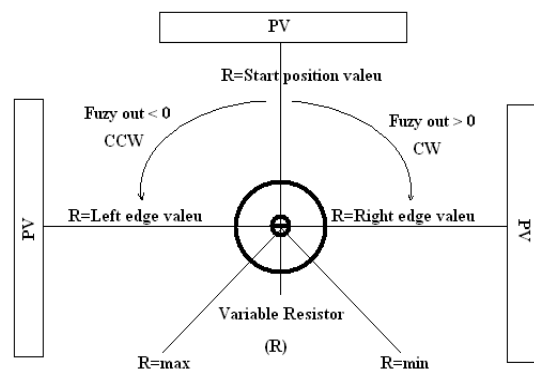

Figure 2. Position Sensor

Figure 3 shows the algorithm of extracting the motor control signals depending on sensors reading and the output of the controller. R is the value of the position sensor, and En is the enable signal to rotate the motor.

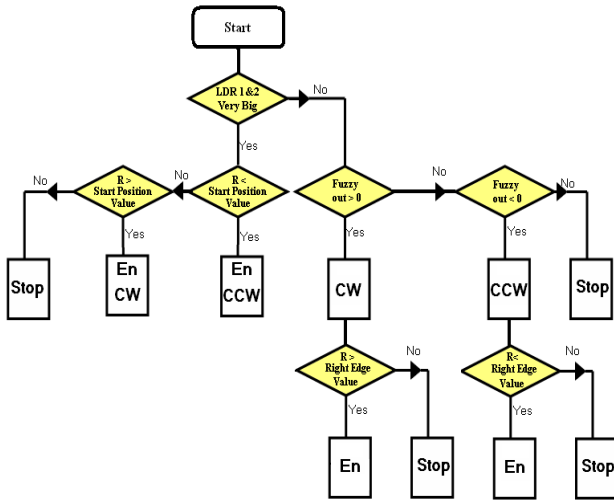

Figure 3. Motor Control Signals Algorithm

III. Fuzzy Logic Controller

FLC has been constructed and the block diagram in Figure 4 shows the FLC for the sun tracker system.

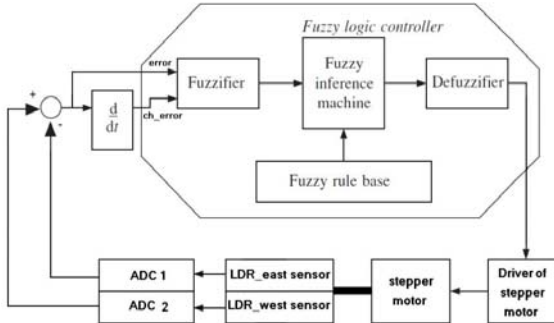

Figure 4. FLC for the Sun Tracker System

A. FLC Design

FLC has two inputs which are: error and the change in error, and one output feeding to the stepper motor driver. There are two widely used approaches in FLC implementation: Mamdani and Sugeno. In this thesis, Mamdani approach has been used to implement FLC for the sun tracker. FLC contains three basic parts: Fuzzification, Base rule, and Defuzzification.

1) Fuzzification

Figure 5 illustrates the fuzzy set of the Error input which contains 7 Triangular memberships.

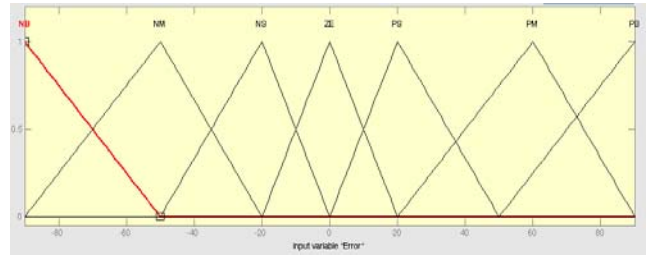

Figure 5. Error Fuzzy Set of FLC.

Figure 6 illustrates the fuzzy set of the Change of Error input which contains 7 Triangular memberships.

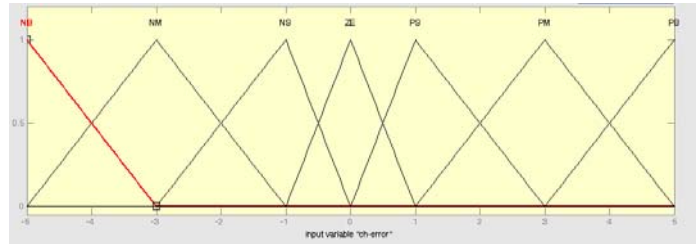

Figure 6. Change in Error Fuzzy Set of FLC.

Figure 7 illustrates the fuzzy set of the output which contains 7 Triangular memberships.

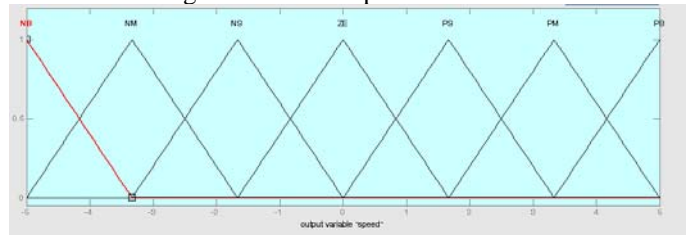

Figure 7. Fuzzy Set of FLC Output Entering to Stepper Motor Driver.

2) Control Rule Base

The knowledge base is defined by the rules for the desired relationship between the input and output variables in terms of the membership functions illustrated in Table I. The control rules are evaluated by an inference mechanism, and represented as a set of:

IF Error is ... and Change of Error is ... THEN the output will

For example: Rule1: IF Error is NS and Change of Error is ZE THEN the output is NS.

The linguistic variables used are:

- NB: Negative Big.
- NM: Negative Medium.
- NS: Negative Small.
- ZE: Zero.
- PS: Positive Small.
- PM: Positive Medium.
- PB: Positive Big.

Table I. Control Rule Base for Fuzzy Controller.

Er \ CE	NB	NM	NS	ZE	PS	PM	PB
NB	NB	NB	NB	NB	NM	NS	ZE
NM	NB	NB	NM	NM	NS	ZE	PS
NS	NB	NM	NS	NS	ZE	PS	PM
ZE	NB	NM	NS	ZE	PS	PM	PB
PS	NM	NS	ZE	PS	PS	PM	PB
PM	NS	ZE	PS	PM	PM	PB	PB
PB	ZE	PS	PM	PB	PB	PB	PB

Figure 8 shows the surface of the base rules using in FLC which is the representation for the inputs and output values of the controller in three dimensions.

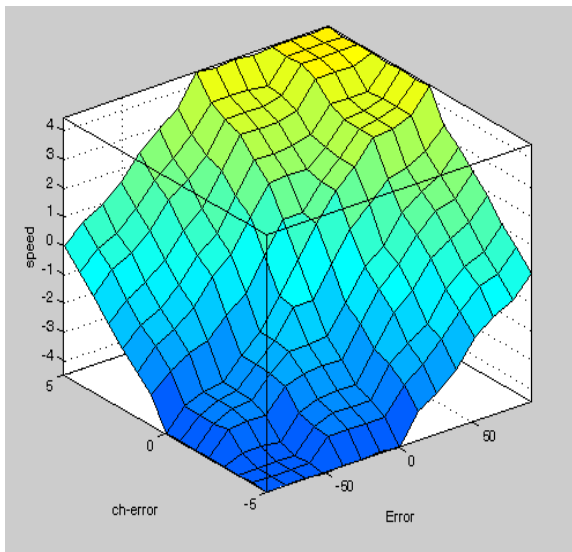

Figure 8. Rule Surface of FLC

3) Defuzzification

The centre of gravity method is widely used in Mamdani approach which has been selected in this paper to compute the output of the FLC, which is the motor speed as:

$$Speed = \frac{\sum_{i=1}^n S_i * \mu(S_i)}{\sum_{i=1}^n \mu(S_i)} \tag{1}$$

IV. FUZZY LOGIC CONTROLLER SIMULATION ON MATLAB/SIMULINK

Figure 9 illustrates the Simulink block diagram for the Fuzzy controller for sun tracker system.

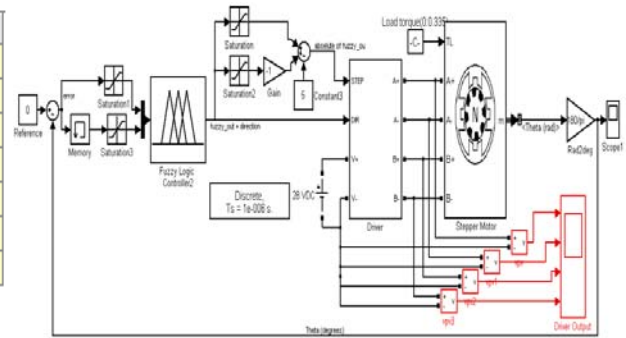
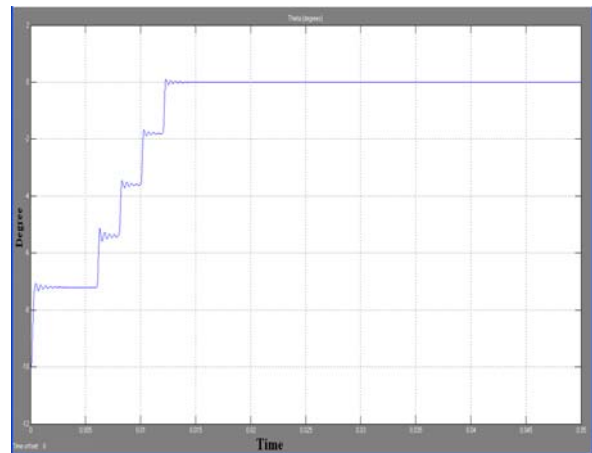

Figure 9. Testing FLC in the Sun Tracker System using Matlab/Simulink



The controller has been tested using Simulink motor module in MATLAB, by applying the step input and initial degree of the rotor is -10 degree. The output step response is shown in Figure 10. The range from -10 to 0 degree takes 5 steps since each step in our motor is 1.8 degree, so (10/1.8)= 5 steps.

Figure 10. Output Degree

Implementing Fuzzy Controller on FPGA

The fuzzy logic controller designed earlier is implemented on Xilinx XC3S700AN FPGA card as shown in Figure 11.

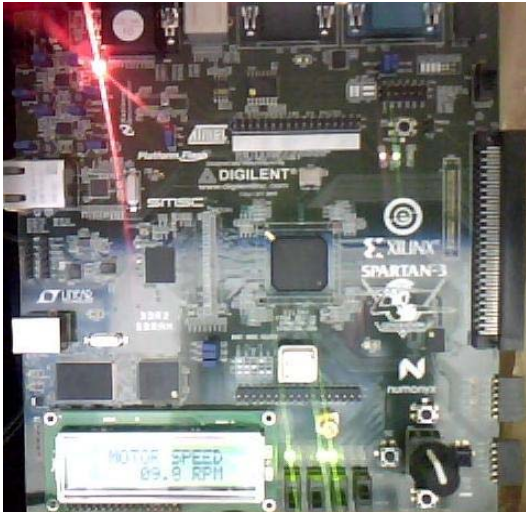

Figure 11. FLC on FPGA Card

Figure 12 shows the RTL schematic diagram in Xilinx software RTL Viewer to view a schematic representation for the FLC and other components after implementing it on Xilinx_ISE 11.1 software. The fuzzy logic controller appears as a red block labelled by name 'FLC', the first input of the controller is error signal takes before differentiator (white block), and other input of the controller is change in error signal takes from after differentiator. The output of the controller is passed through three blocks, the first block which have green color to convert the crisp value to clock wave have a frequency appropriate with this value to control the speed of the motor, the second block which have blue color to extract the other motor control signal such the direction of the motor and the rotation enable signal, the third block which have yellow color (LcdTop block) is for LCD display screen to display the output of the controller. Other blocks are input/output data transfer.

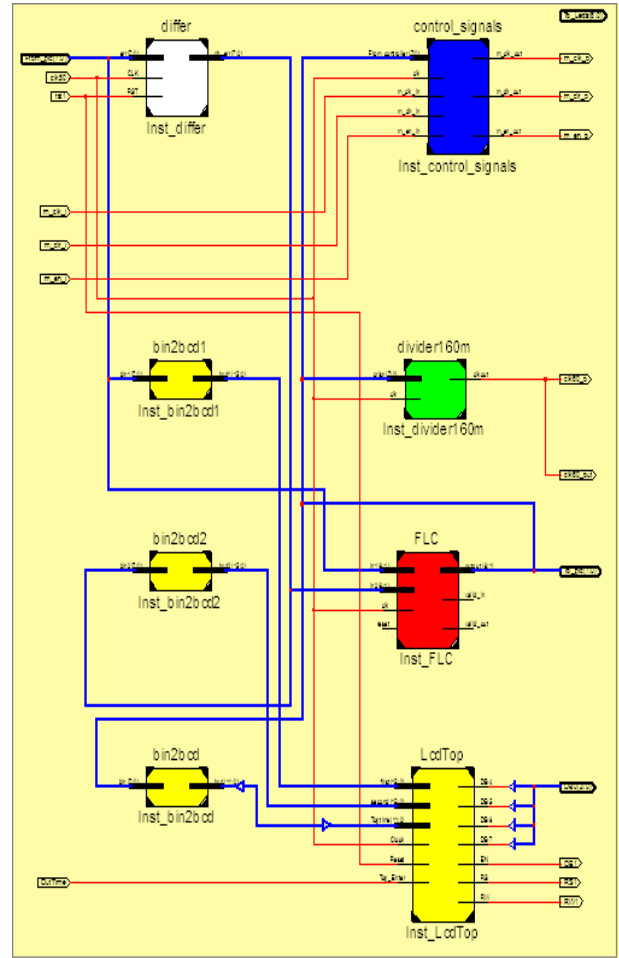

Figure12. RTL Schematic Diagram for FLC with Other Blocks

V. MECHANICAL CONSTRUCTION AND COMPONENTS

System prototype is shown in Figure 14 consists of a mechanical mechanism of 2 degrees of freedom (D.O.F) designed to support and direct a PV solar cell attached to it. Mechanism has the ability to rotate the PV cell about 2_ axes, x or z. But initially, we have locked z- axis rotation and applied control scheme to x- axis only.



Figure 13. System Prototype

Electro- mechanical drive system of x- axis consists of a stepper motor with a 1.5 cm radius pulley attached to its shaft and is driving a 2.5 cm radius pulley attached to main driving shaft as shown in Figure 14, through a belt. Belt mechanism realizes a speed reduction of 40% $((1-1.5/2.5)*100)$, and a torque increase of 40% in order to with stand demand load.

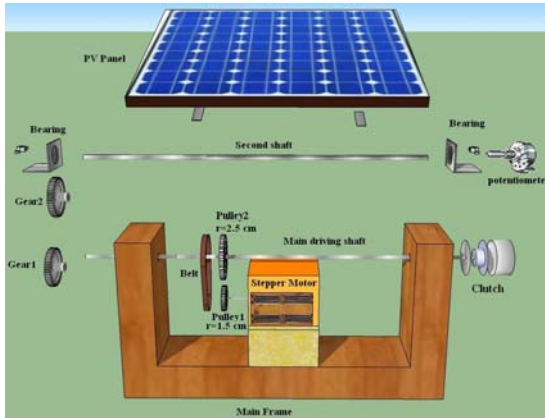

Figure 14. Mechanical Construction and Components

Main driving shaft, shown in Figure 14 is attached to the main frame and supported with two bearings. Also, this shaft is provided by an electro-mechanical clutch in order to prevent axis rotation when driving motor is disabled and to assure to keep the PV panel at the same end position. Main driving shaft transmits rotation to the second shaft, shown in Figure 14, through two identical meshing gears with the same angular speed. Second shaft is supported by the main frame by two ball bearings. PV panel is attached to the second shaft and its angular position is measured with a potentiometer attached to the second shaft end.

IV. Experimental Results

The experimental data of the solar generating power system are measured outdoors in interval from 13 to 17 June, by measuring the voltage and current for the same load in each hour and calculating the average value for all days. Figure 15 represents the power data.

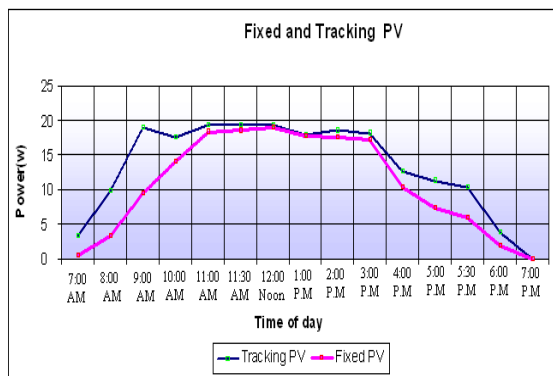

Figure 15. Power Generation Comparison of Fixed Angle Type and Tracking Systems

As shown in Figure 15 the efficiency of solar tracking system is 24% higher than the fixed angle system. It has been shown that the sun tracking systems can collect around 24% more energy than what a fixed panel system collects and thus high efficiency is achieved through the tracker.

IV. CONCLUSION

In this paper, fuzzy logic controller is fabricated on modern FPGA card (Spartan-3AN, Xilinx Company, 2009) to increase the energy generation efficiency of tracking controller received from solar cells. By implementing a sun tracker controller using fuzzy logic controller to keep the PV panel pointing toward the sun by using a stepper motor. The use of stepper motor enables accurate tracking of the sun. LDR resistors are used to determine the solar light intensity. Sun tracking generating power system is designed and implemented in real time. The proposed sun tracking controller and the proposed controller for grid-connected photovoltaic system are tested using Matlab/Simulink program, the proposed FLC shows an excellent result. The proposed solar tracking power generation fuzzy controller is able to track the sun light automatically. It is an efficient system for solar energy collection. It is shown that the sun tracking system using fuzzy controller with FPGA technology is 24% energy efficient than a fixed sun panel system.

REFERENCES

- [1] El-Ashry, M. (2010). *Renewables 2010 Global Status Report*. (Paris: REN21 Secretariat). Copyright Deutsche (GTZ) GmbH.
- [2] Parallax. (2004). *Experiments with Renewable Energy Student Guide*. version 1.
- [3] The Solar Panel How To Guide. (December, 2010). Retrieved from <http://www.solarpanelsbook.com>
- [4] Clean Energy Decision Support Centre. (2001 - 2004) *PHOTOVOLTAIC PROJECT ANALYSIS*. Minister of Natural, Resources Canada.
- [5] K. K. Tse, M. T. Ho, H. Chung, and S. Y. Hui, "A Novel Maximum Power Point Tracker for PV Panels Using Switching Frequency Modulation". *IEEE TRANSACTIONS ON POWER ELECTRONICS*, VOL. 17, NO. 6, NOVEMBER 2002
- [6] Castro, J.L., Fuzzy logic controllers are universal approximators. *IEEE transactions on system, man, and cybernetics*, Vol. 25, No. 4, 629-635.
- [7] Wang, L.X., 1993. Stable adaptive fuzzy control of nonlinear systems. *IEEE Trans. Fuzzy systems*, 1(2): 146-154.
- [8] Wei Zhao, Byung Hwa kim, Amy C. Larson and Richard M. Voyles "FPGA implementation of closed loop control system for small scale robot". *International conference on advanced robotics-ICAR 05*, pages 70- 77, 2005.
- [9] Y.F. Chan, M. Moallem, W. Wang, "Efficient Implementation of PID Control Algorithm using FPGA technology", 43rd IEEE Conference on Decision and Control, December 2004.

- [10] Runghim,T.,Intajag,T. &Krongratana,S. Fuzzy logic PID controller based on FPGA for process control.*IEEE*, Vol.2,No.11, 2004, 1495- 1500.
- [11] G.Sakthivel, T. Anandhi, S. Natarajan, "REAL TIME IMPLEMENTATION OF A FUZZY LOGIC CONTROLLER ON FPGA USING VHDL FOR DC MOTOR SPEED CONTROL" , *International Journal of Engineering Science and Technology*. Vol. 2(9), 2010, 4511-4519.
- [12] Gene,S. & Monroe,J. (2006). Robust Fuzzy Controllers Using FPGAs . NASA LaRC.
- [13] Singh,B., Goyal,R., Kumar,R.&Singh,R. (December 2009). Design and VLSI implementation of Fuzzy Logic Controller.*(IJCNS) International Journal of Computer and Network Security*,Vol. 1, No. 3,



Dr. Basil Hamed is Associate Professor of Electrical Engineering Department, Islamic University of Gaza, Palestine, since 1999. He has Bachelor Degree in Electrical Engineering from New Mexico State University, NM. USA in the year of 1989, he received Master degree from University of New Orleans,

La. USA in the year of 1992, and earned his PhD (Fuzzy Control System) from New Mexico State University, NM USA in the year 1999. He has 15 years of teaching experience and has published many papers in national and international journals. His fields of interest include Control Systems, Fuzzy Control, Simulation & Modeling, FPGA, Genetic Algorithm, SCADA System, Signal and Image Processing.



Mohammed El-Moghany was born on December 25, 1978. He received the B.Sc. and M.Sc. degrees from Islamic University of Gaza, in 2001 and 2011, respectively. His research interests include Fuzzy Logic Control, Renewable Energy, and FPGA.